

## Standardized RP Task Qualifications Study Guide

Standardized RP Task Qualifications	<b>Date:04/16/2024</b>
Title: RP Fundamentals for Junior Task Qualifications	
<b>Author</b>	<b>Theodore J. Green</b>
<b>Reviewed By:</b>	<b>Beverly Gary</b>
<b>Reviewed By:</b>	<b>David Moore</b>
<b>Approved By:</b>	<b>Patty Wade</b>

<b>Revision 1</b>	4/10/2024 Finalization of Draft Material
<b>Revision 2</b>	4/16/24 – Correction “Central Nervous System (CNS) Syndrome – Greater than <b>5000</b> rad, affects the CNS”

**Terminal Objective:** From memory, the trainee will demonstrate knowledge of radiation protection fundamentals as outlined in NISP-RP-012, Training and Qualifications for Supplemental Radiation Protection Technicians.

Mastery of the training material will be demonstrated by a score of 80% or greater on the RP Junior Fundamentals Exam.

Standardized RP Junior Task Qualifications Study Guide  
Lesson RP01.01 Revision 2

EO: 1.1 Define atomic structure including atomic mass units, protons, neutrons, electrons, isotopes, mass-energy equivalence, mass defect, binding energy, and binding energy per nucleon

### ATOMIC STRUCTURE

The three basic particles which make up an atom are the proton, neutron, and electron.

#### Proton

The proton is an elementary particle located in the atom's nucleus. It has a positive electrostatic charge, a mass of  $1.6724 \times 10^{-24}$  grams, and is symbolized by the letter p.

#### Neutron

The neutron is an elementary particle also located in the atom's nucleus. It has no electrostatic charge, a mass slightly greater than the proton at  $1.6747 \times 10^{-24}$  grams, and is symbolized by the letter n.

#### Electron

The electron is an elementary particle which orbits the nucleus. It has a negative electrostatic charge equal in charge intensity to the proton, a mass  $1/1838$  that of a proton, and is symbolized by the letter "e".

An atom consists of the protons and neutrons tightly bound in a central nucleus, surrounded by the electrons orbiting in "shells" or energy levels. The nucleus carries a positive electric charge due to the presence of protons, so that the total charge is the sum of the total number of protons. This positive charge is exactly balanced by the total negative charge of the orbiting electrons, so that the whole atom is electrically neutral. Thus, the number of orbital electrons equals the number of protons in the nucleus for a neutral atom (see the carbon atom example below). The number of electrons determines the atom's chemical properties, which are largely uninfluenced by the nucleus itself.

### NUCLEAR NOTATION

For simplicity, a method for designating any nuclide is commonly used. The definitions of atomic mass number and atomic number are:

- Atomic number (Z) is the number of protons in the nucleus, it defines the element.
- Atomic mass number (A) is the sum of the number of protons and neutrons in the nucleus.

Standardized RP Junior Task Qualifications Study Guide  
 Lesson RP01.01 Revision 2

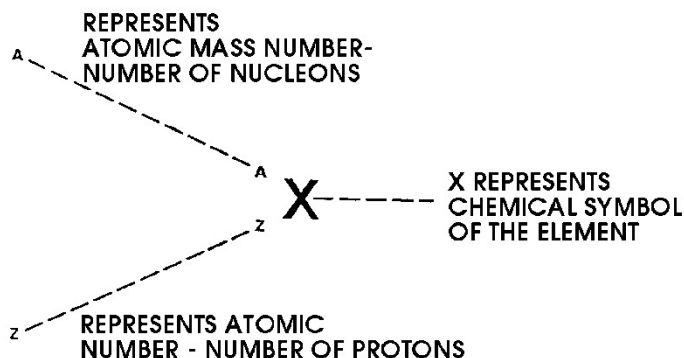

Therefore, the number of neutrons in each nucleus is the difference between the atomic mass number and atomic number.

$$\text{Number of neutrons} = A - Z$$

For example, hydrogen, helium, and uranium atoms are designated as follows:

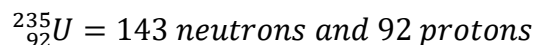
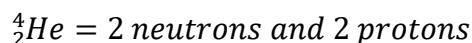
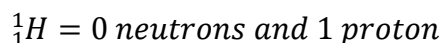

To determine the number of particles in any atom, the following rules apply:

- The number of protons in the nucleus is always equal to the atomic number of the element (Z).
- The number of neutrons is equal to the difference between the atoms atomic mass number and atomic number (A-Z).
- The number of orbital electrons is equal to the number of protons in electrically neutral atoms.

### ATOMIC MASS AND WEIGHT

Since atomic masses are on the order of  $10^{-24}$  grams, a more convenient unit is needed. The standard was chosen to be the "atomic mass unit" (AMU). Where, one atomic mass unit is equal to 1/12 the mass of a carbon 12 nucleus (carbon 12 contains six protons and six neutrons). It is evident that 1 AMU is very nearly the mass of a proton or neutron. The accurately determined value is:

Standardized RP Junior Task Qualifications Study Guide  
Lesson RP01.01 Revision 2

$$1 \text{ AMU} = 1.6605 \times 10^{-24} \text{ gm}$$

The atomic weight of an atom is its mass in AMU. The nuclear mass differs from the atomic weight by the total masses of the electrons. Further, the atomic weight of an element must be considered in detail. A naturally occurring element consists of all those atoms whose nuclei contain a given number of protons, which is the atomic number. For example, the element carbon is made up of all naturally occurring atoms with atomic number 6. However, the atomic number does not completely describe the nucleus, since there may be differing numbers of neutrons included in all nuclei with an atomic number of 6. Nuclei, all of the same atomic number, but possessing different numbers of neutrons are known as the isotopes of the given element. Since the chemical properties of an atom depend solely on the electron structure, the isotopes of an element may also be defined as the set of atoms all having the same chemical nature but differing in atomic weight. Thus, the atomic weight of an element is taken to be the average atomic weight of all the naturally occurring isotopes of that element. Considering the relative isotopic abundances, most elements are composed of 2 or more isotopic types.

Definition: Gram-atomic weight is the atomic weight expressed in grams.

Standardized RP Junior Task Qualifications Study Guide  
Lesson RP01.01 Revision 2

**ELECTRON STRUCTURE**

The chemical properties of atoms are determined by the configuration of the orbiting electrons. Specifically, these properties depend upon the number of electrons in the outermost shell (valence electrons). Each shell represents a different energy level or energy state, the innermost shell representing the lowest energy state - the outermost from a higher energy shell can "drop" into the vacant spot (with X-rays or visible light range energy given off in the process). An atom is in the "ground" state when its electrons are in the innermost or lowest energy level shells. If an electron is in a higher energy shell, the atom is said to be "excited". Each shell has a maximum number of electrons that it will hold. The following table gives the maximum number of electrons for any given shell.

Shell Number	Type of Orbitals	Maximum Number of Electrons in Each Orbital	Maximum Total Electrons in Shell
1 (K)	s	2	2
2 (L)	s	2	8
	p	6	
4 (N)	s	2	32
	p	6	
	d	10	
	f	14	
5 (O)	s	2	50
	p	6	
	d	10	
	f	14	
	g	18	

Standardized RP Junior Task Qualifications Study Guide  
Lesson RP01.01 Revision 2

**MAXIMUM NUMBER OF ELECTRONS PER SHELL**

The table above demonstrates that if there are 2 electrons, they will occupy the K shell. If there are more than 2 and less than 10 electrons, the first 2 electrons are in the K shell and the remaining electrons are in the L shell. If there are more than 10 but less than 28 electrons, the first 2 are in the K shell, the next 8 are in the L shell, and the remaining electrons are in the M shell, etc... However, the outermost shell (valence shell) cannot contain more than 8 electrons.

Atoms with only 1 or 2 valence shell electrons are highly reactive in chemical reactions.

**ONE ELECTRON IN OUTER ORBIT**

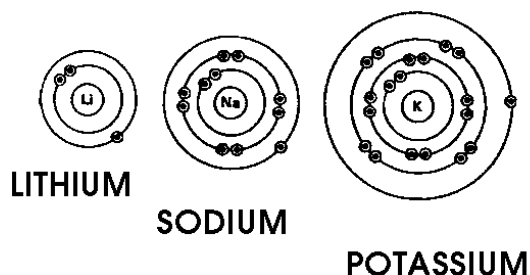

Atoms with a full valence shell normally do not react at all.

**FULL OUTER ORBIT**

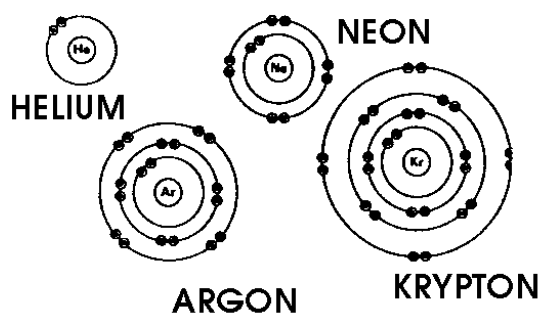

**ISOTOPES**

Not all atoms of a particular element are exactly alike. Hydrogen, for example, exists in three different forms. The most abundant form of hydrogen exists as one proton and one electron. The deuterium atom, an isotope of hydrogen, differs from ordinary hydrogen in that deuterium contains a neutron together with the proton in the nucleus. Tritium, another isotope of hydrogen has two neutrons and one proton in the nucleus. It follows

**Standardized RP Junior Task Qualifications Study Guide**  
**Lesson RP01.01 Revision 2**

that the three isotopes of hydrogen differ in their atomic mass. The figure above illustrates the three isotopes of hydrogen.

**Definition:** Isotopes are atoms that have the same atomic number, but different atomic weights.

When one refers to individual isotopes of an element, it is done in terms of mass number, i.e., the three isotopes of hydrogen would be referred to as: hydrogen-1, hydrogen-2 and hydrogen-3. Most elements exist in nature as a mixture of two or more isotopes. For example, there are two stable isotopes of nitrogen with mass numbers 14 and 15. These isotopes of nitrogen differ only in the fact that N-15 has one more neutron in the nucleus. The electron structure is the same, otherwise the two isotopes would have different chemical properties. Since all isotopes of an element have the same number of protons in the nucleus and the same number and distribution of electrons, we can properly define an element as a substance consisting entirely of atoms having the same atomic number; that is, the same number of protons.

Standardized RP Junior Task Qualifications Study Guide  
Lesson RP01.01 Revision 2

**MASS DEFECT**

When an atom is assembled from its component parts (protons and neutrons and electrons), the total mass of the nuclide is less than the total mass of the individual particles. This mass difference is called the mass defect ( $\Delta m$ ).

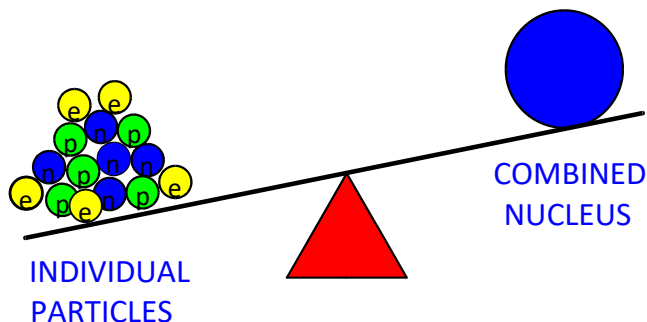

The mass defect is measured in atomic mass units (AMU). One AMU is equal to  $1.66 \times 10^{-24}$  grams. It is possible to calculate the mass defect for each nucleus using the equation below.

$$\Delta m = (Z) m_H + (A - Z) m_n - M$$

Where:

- $\Delta m$  = mass defect (AMU)
- $Z$  = atomic number (number of protons)
- $m_H$  = mass of  $^1_1\text{H}$  atom (1.0078 AMU)
- $A$  = atomic mass number (number of nucleons)
- $m_n$  = mass of a neutron (1.0087 AMU)
- $M$  = mass of the atom

Example: Calculate the mass defect of the U 235 atom. Uranium 235 has a mass of 235.0439 AMU.

$$m = 235.0439 \text{ AMU}$$

$$\Delta m = (Z) m_H + (A - Z) m_n - M$$

Standardized RP Junior Task Qualifications Study Guide  
Lesson RP01.01 Revision 2

$$\Delta m = 92(1.0078) + (235-92)(1.0087) - 235.0439$$

$$\Delta m = 92.7176 + 144.2441 - 235.0439$$

$$\Delta m = 1.9178 \text{ AMU}$$

Of primary concern in nuclear reactions is the question of whether a particular reaction is possible and if so, how much energy is required to initiate the reaction and how much energy is released because of the reaction. The answer to these questions lies in the equivalence of mass and energy.

**Binding Energy**

An atom's mass defect is not mass which just disappears; that is contrary to the laws of conservation. Albert Einstein discovered that mass can be transformed into energy and vice-versa. The missing mass was converted to energy when the nucleus was formed.

**Binding energy** of a nucleus is the energy equivalent in units of Mev of its mass defect.

MASS-ENERGY EQUIVALENCE

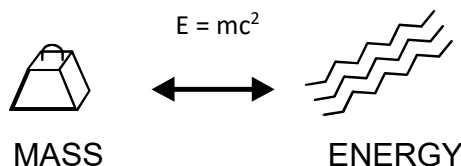

TWO FORMS OF THE SAME THING

In any nuclear reaction, whether it is radioactive decay or fission, the total mass-energy is conserved. That is, binding energy is the amount of energy released when a nucleus is formed from its constituent parts. Conversely, binding energy is the amount of energy which would have to be provided to a nucleus in order to break it apart into separate protons and neutrons. This is of particular importance in calculating the energies of the various types of radiation which accompany the decay of nuclei. In the fission process the mass-energy equivalence allows the calculation of the energy released during the fission reaction.

Incorporating various conversion factors, a simplified equation for the mass defect to energy equivalence results:

$$E(\text{MeV}) = (\Delta m^{\text{AMU}}) 931.5 \frac{\text{Mev}}{\text{Amu}}$$

Example: Determine the energy equivalence of the mass defect of a U-235 atom.

The mass defect for a U-235 atom was 1.9178 AMU.

$$E = (\Delta m^{\text{Amu}}) 931.5 \frac{\text{Mev}}{\text{Amu}}$$

Standardized RP Junior Task Qualifications Study Guide  
 Lesson RP01.01 Revision 2

$$E = (1.9178 \text{ Amu})(931.5 \frac{\text{Mev}}{\text{Amu}})$$

$$E = 1786.4307 \text{ MeV}$$

The Binding Energy per Nucleon provides a better indication of the stability of the nucleus of an atom and is calculated according to the equation:

$$BE/A$$

Example: Determine the binding energy per nucleon of a U-235 atom.

The binding energy for a U-235 atom was 1786.4307 MeV

Therefore, 1786.4307 MeV/235 nucleons = 7.6 MeV/nucleon.

The binding energy per nucleon varies within a relatively narrow range of 5 - 8 MeV for most nuclides.

### ISOTOPIC ABUNDANCE

The abundance of a given element's isotopes is broken down into percentages of a normal mixture of that element. For instance, ordinary copper has an abundance of 69.2% of copper-63 and 30.8% of copper-65. Ordinary silver is composed of 51.83% of silver-107 and 48.17% of silver-109. Carbon has an isotopic abundance of 98.89% carbon-12 and 1.11% carbon-13.

**Definition:** Isotopic abundance is the amount of the isotope (percentage) present in a normal natural mixture of the element.

As an example of an element existing in a natural state, consider uranium. Natural uranium consists of a mixture of isotopes having mass numbers 234, 235 and 238. The next Table lists the isotopic abundances of natural uranium isotopes.

#### COMPOSITION OF NATURAL URANIUM

ISOTOPE	PERCENT ABUNDANCE	ATOMIC MASS
U-234	0.0054%	234.04
U-235	0.7204%	235.04
U-238	99.2742%	238.05
Natural U		238.03

The atomic mass given in the previous Table for natural uranium is a weighted average based on the percent abundance of the atomic mass of each isotope. It is the atomic mass given for uranium on any modern periodic chart. This is the case for all atomic

**Standardized RP Junior Task Qualifications Study Guide**  
**Lesson RP01.01 Revision 2**

masses given in periodic tables in that the table gives the atomic mass of the natural element.

EO: 1.2 Identify nuclear interactions and reactions including radioactive decay, half-life determination, and isotope identification

### THE MODES OF RADIOACTIVE DECAY

Atoms are radioactive when they emit radiation during spontaneous transformation to the atom of another isotope or element. The radiation emitted is either from the nucleus itself or the result of alterations in the orbital electron configuration. The nature of the radiation is a function of the mode of decay of the species. An unstable atom will decay by the emission of radiation in one of the following forms:

1. Alpha particles ( $\alpha$ )
2. Beta particles - positrons, or negatrons ( $\beta$ )
3. Electromagnetic Radiation - gamma ( $\gamma$ ), and X-rays
4. Neutron ( $\eta$ )

The observations made during the early studies of radioactivity have led to the derivation of some mathematical laws and formulas that characterize the rate of radioactive decay or "activity" present in a sample. The most widely used and recognized one of these is called "The Radioactive Decay Law".

It was observed by Rutherford and Soddy that the activity of a sample does not remain constant but changes over a period of time. Thus, from this it may be said that the amount of radioactivity, or the number of radioactive atoms present at any time, is undergoing a consistent continuous change. This change in the number of radioactive atoms follows an orderly process.

If the number of atoms present at a particular time and a factor called their "decay constant" is known, then the exact number of atoms present at some time in the future may be calculated by the formula:

$$N_{\text{Final}} = N_{\text{Initial}} (e^{-\lambda T})$$

$N_{\text{Final}}$  = Number of atoms present at some time in the future

$N_{\text{Init}}$  = Number of atoms present in the initial sample

$\lambda$  = (Lambda) is the decay constant =  $0.693 / t^{1/2}$

$t^{1/2}$  = Half life

T = Elapsed time

Radioactive decay is a purely random process, which means that, of the atoms in a sample undergoing radioactive decay, you cannot identify the particular atom which will

**Standardized RP Junior Task Qualifications Study Guide**  
**Lesson RP01.01 Revision 2**

decay next. The rate of radioactive decay is continuously decreasing with time, due to the fact that the number of atoms undergoing the process of radioactive decay continually decreases with time. The rate of radioactive decay is independent of the present or past state of the substance, or any process that may have occurred to refine or isolate a particular nuclide.

When considering the phenomenon of radioactive decay the following conservation laws must be adhered to for a given generic reaction of  $X_1 + X_2 \rightarrow X_3 + X_4$ , where X is any nuclear or elementary particle.

**Conservation of energy** - In a nuclear reaction the total energy of the system must remain constant.

$$\Delta E_1 + \Delta E_2 = \Delta E_3 + \Delta E_4$$

This energy requirement includes ALL forms of energy:

1. Kinetic Energy
  - a. Linear Momentum must be conserved ( $p = mv$ )
    - i. Total linear momentum of the reactants is equal to the linear momentum of the products.  
 $p_1 + p_2 = p_3 + p_4$
    - ii. The relationship between momentum and the kinetic energy of a particle is expressed as:  
 $E_{Kin} = p^2 / 2m$
2. Electrostatic Energy
  - a. Total Charge of the reaction must be conserved.  
 $Z_1 + Z_2 = Z_3 + Z_4$   
 Where: Z is the charge of the particle in electron units
3. The mass to energy relationship
  - a. The mass number of the reactant and products must be constant.  
 $A_1 + A_2 = A_3 + A_4$

**Decay Phenomena**

Each radionuclide, artificial and natural, has its own characteristic pattern of decay. There are several aspects associated with this pattern:

1. Modes of decay
2. Types of emissions
3. Energies of the emissions involved
4. Rate of decay

Mode of Decay

Standardized RP Junior Task Qualifications Study Guide  
Lesson RP01.01 Revision 2

1. All nuclei of a given radionuclide seeking stability by radioactive decay do so in a specific manner.
2. There are some radioactive nuclides which may decay with branching, whereby a choice of decay modes exists. In such case, a definite branching ratio exists.

Types and energies of Emissions

1. Not only do various radionuclides disintegrate in a constant manner insofar as the types of emissions are concerned, but the emissions from each nuclide exhibit a distinct energy picture.
2. The energies associated with radiations are given in terms of "million electron volts" (MeV).
  - a. Beta emissions may occur with energies to about 5 MeV
  - b. Alpha particles to about 10 MeV
  - c. Gamma photons to about 3 MeV.
3. The energy of the particulate radiations is manifested as kinetic energy--the higher the energy the greater the velocity of the particle.
4. The velocity of photons is constant ( $c$  = speed of light) and energy differences are manifested by varying wavelengths and frequencies.

Rate of Decay

1. The other characteristic aspect associated with decay patterns is the rate of decay, or activity. The disintegrations of radionuclides occur with a regularity characteristic for each species.
2. Such disintegrations are spontaneous and random. A single radium nucleus, for instance, may disintegrate at once or wait thousands of years before emitting an alpha particle.
3. All that can be predicted with any certainty is that half of all the  $^{226}\text{Ra}$  nuclei present will disintegrate in 1,622 years. This period is called the half-life of  $^{226}\text{Ra}$ . Half-lives vary greatly for natural occurring radioisotopes, e.g.,  $^{206}\text{Po}$ , with a half-life of 0.298 microseconds and  $^{232}\text{Th}$ , with a half-life of over  $1.42 \times 10^{10}$  years.

Singly occurring Natural Radionuclides

1. Careful measurements show that almost all materials contain traces of radioactivity.
2. One might suspect that these traces might be due to contamination with some of the heavy radionuclides described. However, some of the lighter elements are themselves weakly radioactive.

Artificial Radioactivity

Standardized RP Junior Task Qualifications Study Guide  
Lesson RP01.01 Revision 2

1. There are radionuclides which occur because of various man-made reactions. These are called artificial radionuclides. Most radionuclides are produced in this manner.
2. As implied in the nomenclature, natural and artificial radioactivity differ in origin. There are other distinctions between the two types which will be discussed.
3. Nevertheless, the nuclei of artificial radionuclides are unstable in much the same manner as their natural counterparts. The intranuclear factors governing decay are also similar for both groups.
4. A brief account of the discovery of artificial radioactivity will be given before further discussing its similarities and dissimilarities to natural radioactivity.

**The Radioactive Decay Law**

The activity of any sample of radioactive material decreases or decays at a fixed rate which is a characteristic of that particular radionuclide.

No known physical or chemical agents (such as temperature, pressure, dissolution, or combination) may be made to influence this rate.

The rate may be characterized by observing the fraction of activity that remains after successive time intervals.

For convenience we choose a fraction that is easy to work with, one-half ( $\frac{1}{2}$ ).

In using this fraction, we can observe the decay of a radionuclide with the passing of time. We can observe how long it takes for the activity to be reduced to one half of the activity.

This time that is required for the activity present to be reduced to Objective 1.06.13 one-half we call the half-life.

If successive half-lives are observed, we can see a reduction each time by a fraction of one-half, and the effect will be cumulative.

1. One half-life reduces to  $(\frac{1}{2})$
2. Two half-lives reduce to  $\frac{1}{2} \times \frac{1}{2} = (\frac{1}{2})^2$  or  $\frac{1}{4}$
3. Three half-lives will reduce to  $\frac{1}{2} \times \frac{1}{2} \times \frac{1}{2} = (\frac{1}{2})^3$  or  $\frac{1}{8}$ .
4. In the general case the fraction of activity remaining after any number of half-lives will be  $(\frac{1}{2})^n$ , where n is the number of half-lives that have elapsed.

To put it still another way, the reduction in activity occurs at an exponential rate, which we have expressed as the power of  $\frac{1}{2}$ .

Radioactive decay occurs at an exponential rate.

1. In using the half-life for our time value, we express this exponential function as  $(\frac{1}{2})^n$ .

Standardized RP Junior Task Qualifications Study Guide

Lesson RP01.01 Revision 2

2. Beginning at the instant chosen as the starting point we have 100% of the activity, since no time has elapsed, and the number of half-lives is zero ( $n = 0$ ).
3. If we use  $t$  to represent time, at this point, then,  $t = 0$ .

If we let  $T_{1/2}$  represent the half-life, then, after one half-life,  $t = T_{1/2}$ , and  $n = 1$ . This demonstrates that  $n$  represents the ratio of time versus the half-life.

Mathematically, this is expressed as:

Obviously, the units of  $t$  must be the same as the time units of  $T_{1/2}$  in order to determine the value of  $n$ .

For example, if the half-life of a certain radionuclide is 10 hours, and we allow 4 hours to elapse, the number of half-lives would be  $4/10 = 0.4$ , or 0.4 half-lives.

The fraction remaining at that instant where  $t = 4$  hours would be:

The activity at the instant where  $t = 0$  is the initial or original activity, represented as  $A_0$ .

The activity at any time  $t$  after 0 we will denote as  $A_t$ .

## EO: 1.3 Describe the fission process and affects from neutron leakage

When a free neutron strikes a nucleus, one of the processes which may occur is the *absorption* of the neutron by the nucleus. It has been shown that the absorption of a neutron by a nucleus raises the energy of the system by an amount equal to the binding energy of the neutron. Under some circumstances, this absorption may result in the splitting of the nucleus into at least two smaller nuclei with an accompanying release of energy.

This process is called *fission*. Two or three neutrons are usually released during this type of transformation.

To account for how this process is possible, use is made of the liquid drop model of the nucleus. This model is based on the observation that the nucleus, in many ways, resembles a drop of liquid. The liquid drop is held together by cohesive forces between molecules, and when the drop is deformed the cohesive forces may be insufficient to restore the drop to its original shape. Splitting may occur, although in this case, there would be no release of energy.

The absorption of a neutron raises the energy of the system by an amount equal to the binding energy of the neutron. This energy input causes deformation of the nucleus, but if it is not of sufficient magnitude, the nucleon-nucleon attractive forces will act to return the nucleus to its original shape. If the energy input is sufficiently large, the nucleus may reach a point of separation, and fission has occurred. The energy required to drive the nucleus to the point of separation is called the *critical energy for fission*,  $E_c$ . The values of  $E_c$  for various nuclei can be calculated, based on knowledge of the forces which act to hold the nucleus together.

An example of fission is shown below, involving neutron absorption by  $^{235}\text{U}$ :

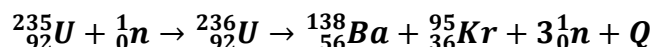

Where  $Q$  = energy

On the average, approximately 200 MeV of energy is released per fission.

The fission process can be "energetically" explained by comparing the critical energy for fission with the amount of energy input, i.e., the neutron binding energy. For  $^{238}\text{U}$  and  $^{232}\text{Th}$ , the critical energy for fission is greater than the neutron binding energy. Therefore, an additional amount of energy must be supplied for fission to occur in these nuclei. This additional energy is in the form of neutron kinetic energy, and confirms the observation

### Standardized RP Junior Task Qualifications Study Guide Lesson RP01.01 Revision 2

that fission occurs in these fissionable nuclei only when the neutron has approximately 1 MeV of kinetic energy.

The situation is quite different for  $^{235}\text{U}$ ,  $^{233}\text{U}$ , and  $^{239}\text{Pu}$ . In these cases, the neutron binding energy exceeds the critical energy for fission. Thus, these nuclei may fission by *thermal*, or very low energy, (0.025 eV) neutrons. The new elements which are formed because of the fission of an atom are unstable. To attain stability, the fission fragments will undergo various transformations depending on the degree of instability.

Along with the neutrons immediately released during fission, a highly unstable element may give off several neutrons to try to regain stability. This, of course, makes more neutrons available to cause more fission and is the basis for the *chain reaction* used to produce nuclear power. The excited fission product nuclei will also give off other forms of radiation in an attempt to achieve a stable status. These include beta and gamma radiation.

EO: 1.4 Describe the basic characteristics of BWRs and PWRs, including fission product barriers

In a typical design concept of a commercial Boiling Water Reactor (BWR), the following process occurs:

1. The core inside the reactor vessel creates heat.
2. A steam-water mixture is produced when very pure water (reactor coolant) moves upward through the core, absorbing heat.
3. The steam-water mixture leaves the top of the core and enters the two stages of moisture separation where water droplets are removed before the steam is allowed to enter the steam line.
4. The steam line directs the steam to the main turbine, causing it to turn the turbine generator, which produces electricity.

The unused steam is exhausted to the condenser, where it is condensed into water. The resulting water is pumped out of the condenser with a series of pumps, reheated, and pumped back to the reactor vessel. The reactor's core contains fuel assemblies that are cooled by water circulated using electrically powered pumps. These pumps and other operating systems in the plant receive their power from the electrical grid. If offsite power is lost, emergency cooling water is supplied by other pumps, which can be powered by onsite diesel generators. Other safety systems, such as the containment cooling system, also need electric power. BWRs contain between 370-800 fuel assemblies.

In a typical design concept of a commercial Pressurized Water Reactor (PWR), the following process occurs:

1. The core inside the reactor vessel creates heat.
2. Pressurized water in the primary coolant loop carries the heat to the steam generator.
3. Inside the steam generator, heat from the primary coolant loop vaporizes the water in a secondary loop, producing steam.
4. The steam line directs the steam to the main turbine, causing it to turn the turbine generator, which produces electricity.

The unused steam is exhausted to the condenser, where it is condensed into water. The resulting water is pumped out of the condenser with a series of pumps, reheated, and pumped back to the steam generator. The reactor's core contains fuel assemblies that are cooled by water circulated using electrically powered pumps. These pumps and other operating systems in the plant receive their power from the electrical grid. If offsite power is lost, emergency cooling water is supplied by

**Standardized RP Junior Task Qualifications Study Guide**  
**Lesson RP01.01 Revision 2**

The first fission product barrier for both BWR and PWR is the fuel cladding, with the second barrier being the reactor system piping. The third fission product barrier is the containment structure.

Standardized RP Junior Task Qualifications Study Guide  
Lesson RP01.01 Revision 2

EO: 1.5 Describe the statistical nature of radioactive decay as it relates to uncertainties encountered when measuring radioactivity

Radiological sample analysis involves observation of a random process, one that may or may not occur, and estimation of the amount of radioactive material present based on that observation. All over the country radiation protection personnel are using activity measurements to make decisions that may affect the health and safety of workers at those facilities and their surrounding environments.

This unit presents an overview of measurement processes, and statistical evaluation of both measurements and equipment performance. In addition, this unit addresses some of the actions to take to minimize the sources of error in count room operations.

### GENERAL SOURCES OF ERROR

Assuming the counting system is calibrated correctly, there are five general sources of error associated with **counting** a sample:

1. *Self-absorption*
2. *Backscatter*
3. *Resolving time*
4. *Geometry*
5. *Random disintegration* of radioactive atoms (statistical variations).

#### Self-Absorption

When a sample has an abnormally large amount of material on the sample media, it could introduce a counting error due to *self-absorption*, which is the absorption of the emitted radiation by the sample material itself. Self-absorption could occur for:

- Liquid samples with a high solid content
- Air samples from a high dust area
- Use of improper filter paper may introduce a type of self-absorption, especially in alpha counting (i.e., absorption by the media, or filter).

Personnel counting samples should ensure the correct sample media is used, and that the sample does not become too heavily loaded with sample material. Count room personnel should be routinely checking samples for improper media or heavily loaded samples.

#### Backscatter

Counting errors due to *backscatter* occur when the emitted radiation traveling away from the detector is reflected, or scattered back, to the detector by the material behind the sample. The amount of radiation that is scattered back will depend upon the type

Standardized RP Junior Task Qualifications Study Guide  
 Lesson RP01.01 Revision 2

and energy of the radiation and the type of backing material (reflector). The amount of backscattered radiation increases as the energy of the radiation increases and as the atomic number of the backing material increases. Generally, backscatter error is only a consideration for particulate radiation, such as alpha and beta particles. Because beta particles are more penetrating than alpha particles, backscatter error will be more pronounced for beta radiation. The ratio of measured activity of a beta source counted with a reflector compared to counting the same source without a reflector is called the:

$$BF(\text{Backscatter Factor}) = \frac{\text{counts with reflector}}{\text{counts without reflector}}$$

Normally, backscatter error is accounted for in the efficiency or conversion factor of the instrument. However, if different reflector materials, such as aluminum and stainless steel, are used in calibration and operation, an additional unaccounted error is introduced. (This additional error will be about 6% for stainless steel versus aluminum.) Count room personnel must be aware of the reflector material used during calibration of the counting equipment. Any deviation from that reflector material will introduce an unaccounted error and reduce confidence in the analysis results.

**Resolving Time**

*Resolving time* is the time interval which must elapse after a detector pulse is counted before another full-size pulse can be counted. Any radiation entering the detector during the resolving time will not be recorded as a full-size pulse; therefore, the information on that radiation interaction is lost. As the activity, or decay rate, of the sample increases, the amount of information lost during the resolving time of the detector is increased. As the losses from resolving time increase, an additional error in the measurement is introduced.

Resolving time losses can be corrected by using the equation:

$$R = \frac{R_o}{1 - R_o\tau}$$

where:

$R$  = "true" count rate, in cpm

$R_o$  = observed count rate, in cpm

$\tau$  = resolving time of the detector, in minutes ("tau")

Count room personnel should be aware of the limitations for sample count rate, based upon procedures and the type of detector in use, to prevent the introduction of additional resolving time losses. This is especially true for counting equipment that uses GM detectors.

**Geometry**

*Geometry* related counting errors result from the positioning of the sample in relation to the detector. Normally, only a fraction of the radiation emitted by a sample is emitted in the direction of the detector because the detector does not surround the sample. If the distance between the sample and the detector is varied, then the fraction of emitted radiation which hits the detector

### Standardized RP Junior Task Qualifications Study Guide Lesson RP01.01 Revision 2

will change. This fraction will also change if the orientation of the sample under the detector (i.e., side-to-side) is varied.

An error in the measurement can be introduced if the geometry of the sample and detector is varied from the geometry used during instrument calibration. This is especially critical for alpha counting, where any change in the sample-to-detector distance also increases (or decreases) the chance of attenuation of the alpha particles by the air between the sample and detector.

Common sources examples of geometry-related errors include:

- Piling smears and/or filters on top of each other in the same sample holder (moves the top sample closer to the detector and varies the calibration geometry).
- Using deeper or shallower sample holders than those used during calibration (changes the sample-to-detector distance).
- Adjusting movable bases in the counting equipment sliding drawer (changes the sample-to-detector distance).

Using too many or inappropriate sample holders or planchets (changes the sample-to-detector distance). Sources not fixed in position can change geometry and reduce reproducibility.

- Plexiglass shelving in counting chamber is improperly set.

#### Random Disintegration

The fifth source of general counting error is the *random disintegration* of the radioactive atoms and constitutes the remainder of the lesson.

#### STATISTICS

*Statistics* is a branch of mathematics that deals with the organization, analysis, collection, and interpretation of statistical data. No definition of *statistical data* is given. However, Webster's does define a statistic as "an estimate of a variable, as an average or a mean, made on the basis of a sample taken from a larger set of data." This last definition is applicable to our discussion of counting statistics.

After all, when we take samples, we use the data derived from analysis of those samples to make determinations about conditions in an area, in water, or in air, etc., assuming that the sample is representative.

So, we have estimated conditions (a variable) based on a sample (our smear, water sample, air sample) taken from a larger set of data.

Over the years, various methods and observations have identified three models which can be applied to observations of events that have two possible outcomes (binary processes). Luckily, we can define most observations in terms of two possible outcomes.

**Standardized RP Junior Task Qualifications Study Guide**  
**Lesson RP01.01**  
**Revision 2**

Test	Probability of Process What is success	Probability
Flipping a coin	Tails	1 of 2
Rolling a dice	Number 5	1 of 6
Radioactive decay	Nucleus loss during specific time	$1 - e^{-\lambda t}$

For each of the processes that we want to study, we have defined a *trial* (our test), a *success* and a *failure* (two possible outcomes) and have determined the *probability* of observing our defined success.

Now, to study these processes, we can use proven, statistical models to evaluate our observations for error. Consider the possibilities when throwing two dice.

**Possible outcomes for two die**

Result	Opportunities	# Of Opportunities
2	1 & 1	1
3	1&2, 2&1	2
4	2&2, 1&3, 3&1	3
5	2&3, 3&2, 4&1, 1&4	4
6	2&4, 1&5, 4&2, 5&1, 3&3	5
7	1&6, 3&4, 4&3, 5&2, 2&5, 6&1	6
8	2&6, 3&5, 4&4, 5&3, 6&2	5
9	3&6, 4&5, 5&4, 6&3	4
10	4&6, 5&5, 6&4	3
11	5&6, 6&5	2
12	6&6	1

If, in our study of this process, we define a success as throwing a number between 2 and 12, the outcome is academic. All trials will be successful, and we can describe the probabilities of throwing any individual number between the range of 2 and 12 inclusive would add up to 1. If we define a success as throwing a particular number, we can define the probability of our success in terms of the number of possible outcomes that would give us that number in comparison to the total number of possible outcomes.

**Binomial Distribution**

This is the most general of the statistical models and is widely applicable to all processes with a constant probability. It is not widely used in nuclear applications because the mathematics are too complex.

**Poisson Distribution**

A simplified version of binomial distribution is the *Poisson* (pronounced "pwusówn") distribution, which is **valid when the probability of success, P(x), is small**. If we graphed a Poisson distribution function, we would expect to see the predicted number of successes at the lower end of the curve, with successes over the entire range if sufficient trials were attempted.

### Standardized RP Junior Task Qualifications Study Guide Lesson RP01.01 Revision 2

#### Gaussian Distribution

Also called the "normal distribution," the *Gaussian* (pronounced "Gowziun") distribution is a further simplification which is **applicable if the average number of successes is relatively large, but the probability of success is still low**. A graph of a Gaussian distribution function is shown on page 28.

Note that the highest number of successes is at the center of the curve, the curve is a bell-shaped curve, and the relative change in success from one point to the adjacent is small. Also note that the mean, or average number of successes, is at the highest point, or at the center of the curve.

The Gaussian, or normal, distribution is applied to counting applications where the mean success is expected to be greater than 20. It is used for counting system calibrations and operational checks, as well as for normal samples containing activity. It may or may not include environmental samples (i.e., samples with very low activity).

#### APPLICATION OF STATISTICAL MODELS

Application of specific statistical methods and models to nuclear counting operations is termed *counting statistics* and is essentially used to do two things:

- **Predict the inherent statistical uncertainty associated with a single measurement**, thus allowing us to estimate the precision associated with that measurement.
- **Serve as a check** on the normal function of nuclear counting equipment.

#### DEFINITIONS

**Mode** An individual data point that is repeated the most in a particular data set.

**Median** The center value in a data set arranged in ascending order.

**Mean** The average value of all the values in a data set.

Standardized RP Junior Task Qualifications Study Guide  
Lesson RP01.01 Revision 2

Example Data Set

Student	Test Score
Robert	80
Fred	82
Alicia	86
Jerry	88
Beverly	90
Cari	92
Brian	95
Peter	95
Bruce	95

- Determination of the Mode: In the set of test scores above, a score of 95 occurs (i.e., is repeated) more often than any other score.
- Determination of the Median: In the same set of test scores, this is the score in the middle - where one half of the scores are below, and the other half are above the median. The median for the test scores in Figure 4 is 90.
- Determination of the Mean: This is found by adding all of the values in the set together and dividing by the number of values in the set. The mean of the nine test scores is 89.

Mean determination is often expressed using special symbols, as illustrated in the following equation:

$$\bar{x} = \frac{\sum x_i}{n}$$

where:

$\bar{x}$  = mean (also referred to as “x bar”)

$x_i$  = data point with index  $i$

$n$  = number of data points

$$\sum = \text{summation symbol} \rightarrow \sum_{i=1}^n x_i = x_1 + x_2 + x_3 + \dots + x_n$$

Standardized RP Junior Task Qualifications Study Guide  
 Lesson RP01.01 Revision 2

**VARIANCE AND STANDARD DEVIATION**

Using the Gaussian distribution model depicted in Figure 4 (below) we need to define the terms "variance" and "standard deviation," which are both used as descriptors of the spread of the population (or the data set) in a normal distribution.

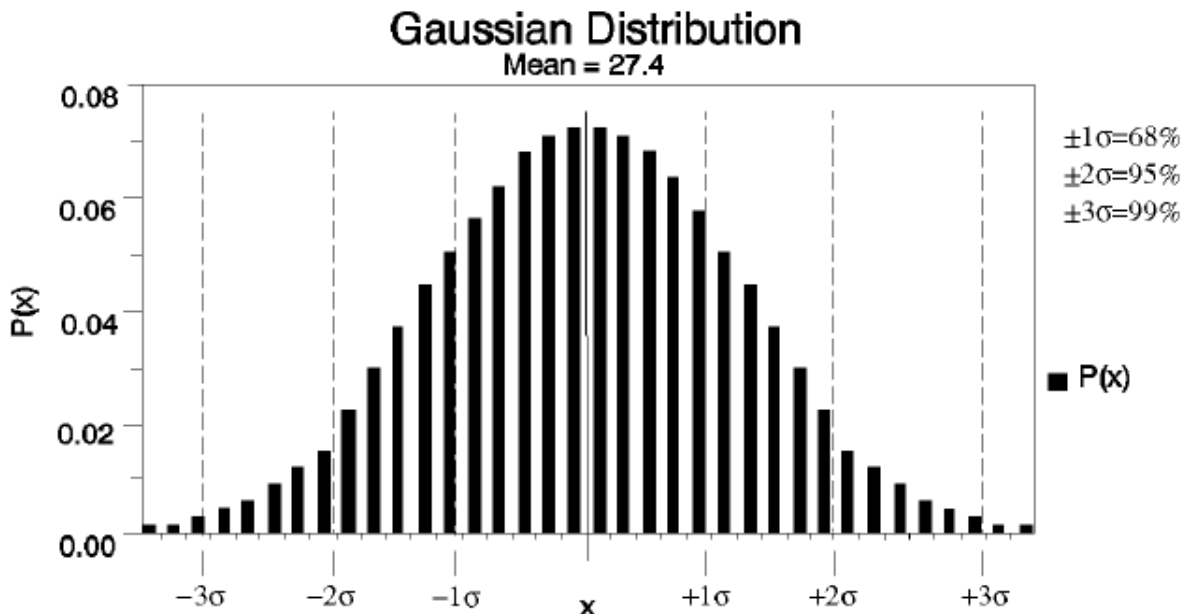

**Variance** -The amount of scatter of data points around the mean is defined as the sample *variance*. In other words, it tells how much the data "varies" from the mean.

**Standard Deviation** Mathematically, in the normal distribution, the standard deviation is **the square root of the variance**. A term more precise than the variance is *standard deviation*, represented by a  $\sigma$  (pronounced "sigma"). The standard deviation of a population is defined mathematically as:

$$\sigma = \sqrt{\frac{\sum(x_i - \bar{x})^2}{n}}$$

Where:

$\sigma$  = biased standard deviation of the population

$x_i$  = sample counts for each data point

$\bar{x}$  = mean

$n$  = number of data points

If most of the data points are located close to the mean, the curve will be tall and steep and have a low numerical value for a standard deviation. If data points are scattered, the curve will be lower and not as steep and have a larger numerical value for a standard deviation.

### Standardized RP Junior Task Qualifications Study Guide Lesson RP01.01 Revision 2

In a Gaussian distribution, it has been determined mathematically that 68.2% of the area under the curve falls within the data point located at the mean  $\pm$  (plus or minus) one standard deviation ( $1\sigma$ ); 95.4% of the area under the curve falls between the data point located at  $\pm$  two standard deviations ( $2\sigma$ ), etc. What this means to us in terms of counting processes is that if the distribution (as depicted in Figure 5) is representative of a counting function with a mean observable success  $>20$  (Gaussian distribution):

- 68.2% of the time the observed successes (or counts) will be within  $\pm 1$  standard deviation of the mean.
- 95.4% of the time the observed successes (or counts) will be within  $\pm 2$  standard deviations of the mean.
- 99.97% of the time the observed successes (or counts) will be within  $\pm 3$  standard deviations of the mean.

Remember, the area of the curve represents the probability of success in a random process. In radiation protection this random process is the decay of a radioactive sample. The known statistical distribution is used in radiation protection when setting up a counting system and in evaluating its operation by means of daily pre-operational source checks. In performing the calibration of the system, a radioactive source with a known activity is counted twenty times for one minute each time. Using the data from the twenty counts, the mean and standard deviation can be calculated. The mean can then be used to determine the efficiency of the system while allowing for a certain number of standard deviations during operation.

The two parameters of interest for a detector system with a background response greater than zero are:

- $L_C$  - Critical detection level: the response level at which the detector output can be considered "above background"
- $L_D$  - Minimum significant activity level, i.e., the activity level that can be seen with a detector with a fixed level of certainty

Standardized RP Junior Task Qualifications Study Guide  
 Lesson RP01.01 Revision 2

I = Probability of Type I error  
 II = Probability of Type II error

B = Background  
 L<sub>C</sub> = Critical detection level  
 L<sub>D</sub> = Minimum significant activity level

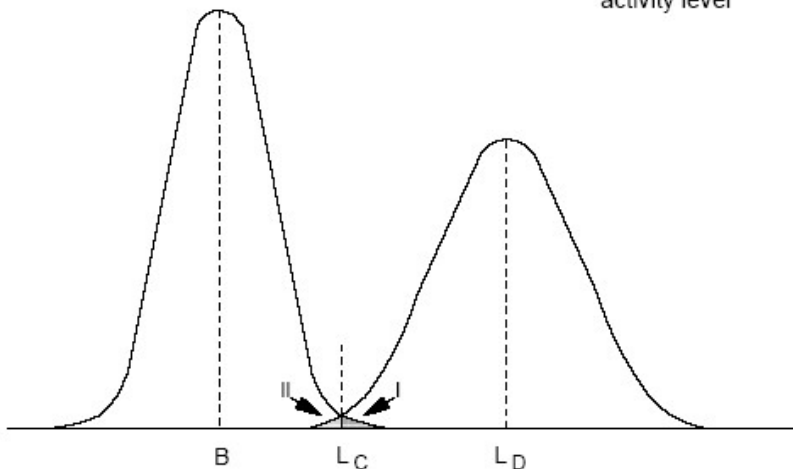

Figure 6. Errors in Detection Sensitivity

The above picture demonstrates the problem found in counting sources/items that are at or near the background level. We see that the distributions from background and a potential source near background overlap. The critical detection level (L<sub>c</sub>) is the point where the two distributions meet/overlap. The critical detection level is defined as a net signal at which one may decide if the result of an analysis indicates detection. It is nearly impossible to separate the two distributions, so we must use a method to distinguish true activity from background to an acceptable confidence level.

**Minimum Detectable Counting Rate (MDCR)** the sample activity which produces a count rate that is statistically different from background

$$MDCR(cpm) = \frac{2.71}{T_s} + \left( 3.29 \sqrt{\frac{B}{T_b} + \frac{B}{T_s}} \right)$$

The methods used distinguish true activity from background to an acceptable confidence level is the purpose of the minimum detectable counting rate (MDCR) and the subsequent minimum detectable activity (MDA). MDCR may be defined as the sample activity which produces a counting rate statistically different than the background rate. A confidence

Standardized RP Junior Task Qualifications Study Guide  
Lesson RP01.01 Revision 2

level of 95% is used for the MDCR to correctly determine whether activity is present or absent. This corresponds to a 5% probability of either a Type I or a Type II error.

Note: Units on this equation will not cancel out.

**Minimum Detectable Activity** – sample activity which produces count rate statistically different than background, accounting for efficiency

$$MDA = \frac{MDCR}{E}$$

Where:  $MDA$  = minimum detectable activity in dpm  
 $MDCR$  = minimum detectable count rate in cpm  
 $E$  = efficiency

EO: 1.6 Describe the use of the Chart of Nuclides.

Chart of the Nuclides (Ref required for the student)

1. General Arrangement
  - a. In arranging the nuclides in chart form, the number of neutrons (N) is plotted horizontally on the x-axis against the number of protons (atomic number, Z) on the y-axis
  - b. Such a plot at once reveals the continuity in composition in progressing from the lighter to the heavier elements. Post Chart in classroom or provide books for students to use during discussion.
  - c. The full-size Chart of the Nuclides (poster) is much easier to follow than the Nuclides and Isotopes volume which contains all of the material from the chart in book form. A guide for using the chart is found in the book.
2. Specific Nuclide Representation
  - a. Each specific nuclide is represented in the Chart of the Nuclides by a block.
  - b. The coloring and labeling of each block specifies certain information concerning the properties of the nuclide.
  - c. Values for atomic number (Z) are given along the left side of the grid, and values for number of neutrons (N) are found along the bottom.
  - d. A grey block denotes a stable nuclide. A typical example is Sodium-23.
  - e. Unlike sodium, most elements have more than one stable isotope. For example, magnesium (Mg) has three stable isotopes

EO: 1.7 Identify the types of radioactive decay.

#### Modes of Decay and Types of Radioactive Emissions

1. Rutherford was initially able to identify three types of radiation resulting from radioactive decay: alpha, beta and gamma. Initially, all three radiations were commonly referred to as rays.
2. With time, the characteristics of each of these radiations were determined. It was found that alpha and beta are particulate radiations, not rays. Since then, other radiations have been discovered through numerous experiments and tests.
3. When a radioactive nuclide decays, a transmutation occurs. The decay product, or daughter has become an atom of a new element with chemical properties entirely unlike the original parent atom. With each transmutation an emission from the nucleus occurs. There are several modes of decay and emissions associated with each mode.

EO: 1.8 Describe each type of decay using basic equations.

## Alpha Decay

With a few exceptions, only relatively heavy radioactive Objective 1.06.04 a. nuclides decay by alpha emission.

An alpha particle is essentially a helium nucleus. It consists of two protons and two neutrons, giving it a mass of 4 amu.

*Because of the two protons it has an electric charge of +2.*

The symbol  $\alpha$  is used to designate alpha particles.

A nucleus emitting an alpha particle will decay to a daughter element, reduced in atomic number ( $Z$ ) by 2 and reduced in mass number ( $A$ ) by 4. The standard notation for alpha decay is:

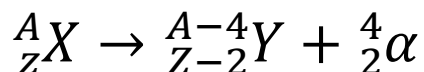

For example, Radium-226 decays by alpha emission to produce Radon-222 as follows

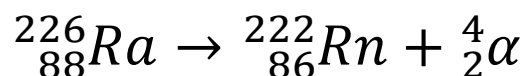

Alpha particles are the least penetrating of the three types of radiation. They can be absorbed or stopped by a few centimeters of air or a sheet of paper.

## Beta Decay

A nuclide that has an excess number of neutrons (i.e., the n:p ratio is high) will usually decay by beta emission. The intra-nuclear effect would be the changing of a neutron into a proton, thereby decreasing the n:p ratio, resulting in the emission of a beta particle.

Beta particles are negatively charged particles. They have the same mass as an electron (1/1836 of proton or 5.49E-4 amu) as well as the same charge (-1) and can be considered high speed electrons.

Standardized RP Junior Task Qualifications Study Guide  
Lesson RP01.01 Revision 2

Because of the negative charge of the beta particle, beta emission is often more explicitly referred to as "beta-minus" emission (the particle sometimes being referred to as a negatron).

Beta particles originate in the nucleus, in contrast with ordinary electrons, which exist in orbits around the nucleus.

The symbol  $\beta$  is used to designate beta particles.

In beta-minus emitters, the nucleus of the parent gives off a negatively charged particle, resulting in a daughter more positive by one unit of charge. Because a neutron has been replaced by a proton, the atomic number increases by one, but the mass number is unchanged.

In order to conserve energy and momentum between the parent and the daughter plus beta particle there is also the emission of an antineutrino, symbolized by the Greek letter nu with a bar above it ( $\bar{\nu}$ )

The standard notation for beta decay is:

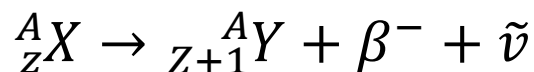

For example, Lead-210 decays by beta-minus emission to produce Bismuth-210 as follows:

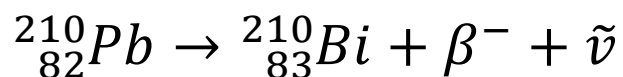

Beta particles are emitted with kinetic energies ranging up to the maximum value of the decay energy,  $E_{\max}$ . The average energy of beta particles is about  $1/3E_{\max}$ .

They travel several hundred times the distance of alpha particles in air and require a few millimeters of aluminum to stop them.

Neutrinos ( $\nu$ ) and anti-neutrinos ( $\bar{\nu}$ ) are neutral (uncharged) particles with negligible rest mass, travel at the speed of light and are very non-interacting. They account for the energy distribution among positrons and beta particles from given radionuclides in the positron- and beta-decay processes respectively.

### Positron Decay

**Standardized RP Junior Task Qualifications Study Guide**  
**Lesson RP01.01 Revision 2**

A nuclide that has a low n: p ratio (too many protons) will tend to decay by positron emission.

A positron is often mistakenly thought of as a positive electron. If positive electrons existed, then when they encountered an ordinary negative electron, the Coulomb force would cause the two particles to accelerate toward each other. They would collide and then the two equal, but opposite charges would mutually cancel. This would leave two neutral electrons.

A positron is the anti-particle of an electron. This means that it has the opposite charge (+1) of an electron (or beta particle). Thus, the positron is a positively charged, high-speed particle which originates in the nucleus.

Because of its positive charge and a rest mass equal to that of a beta particle, a positron is sometimes referred to as "beta-plus."

The symbol  $\beta^+$  is used to designate positrons. With positron emitters, the parent nucleus changes a proton into a neutron and gives off a positively charged particle.

This results in a daughter less positive by one unit of charge. Because a proton has been replaced by a neutron, the atomic number decreases by one and the mass number remains unchanged.

The emission of a neutrino (symbolized by  $\nu$ ) also occurs in conjunction with the positron emission.

Positron decay is illustrated by the following notation:

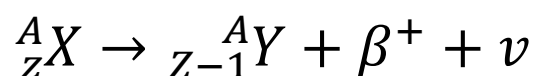

For example, Nickel-57 decays by positron emission:

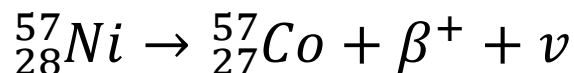

## Electron Capture

For radionuclides having a low n: p ratio, another mode of decay can occur known as orbital electron capture (EC).

**Standardized RP Junior Task Qualifications Study Guide**  
**Lesson RP01.01 Revision 2**

In this radioactive decay process the nucleus captures an electron from an orbital shell of the atom, usually the K shell, since the electrons in that shell are closest to the nucleus. This mode of decay is frequently referred to as K-capture. The nucleus might conceivably capture an L shell electron, but K electron capture is much more probable.

The transmutation resembles that of positron emission, as follows:

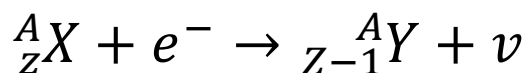

The electron combines with a proton to form a neutron, followed by the emission of a neutrino.

Electrons from higher energy levels immediately move in to fill the vacancies left in the inner, lower-energy shells. The excess energy emitted in these moves results in a cascade of characteristic X-ray photons.

Either positron emission or electron capture can be expected in nuclides with a low neutron to proton ratio.

The intra-nuclear effect of either mode of decay would be to change a proton into a neutron, thus increasing the n: p ratio.

Note that  $\text{Ni}^{57}$  has two modes of decay. This is an example of branching which is explained in the section DECAY PHENOMENA.

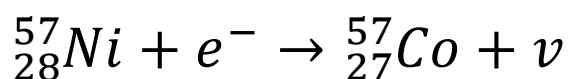

## Gamma Emission

Gamma emission is another type of radioactive decay. Nuclear decay reactions resulting in a transmutation generally leave the resultant nucleus in an excited state. Nuclei, thus excited, may reach an unexcited or ground state by emission of a gamma ray.

Gamma rays are a type of electromagnetic radiation. They behave as small bundles or packets of energy, called photons, and travel at the speed of light.

The symbol  $\gamma$  is used to designate gamma radiation.

Standardized RP Junior Task Qualifications Study Guide  
 Lesson RP01.01 Revision 2

Since the gamma decay doesn't involve the gain or loss of protons or neutrons, the general equation is slightly different from the other decay equations.

For all intents and purposes, gamma radiation is the same as X-rays. Gamma rays are usually of higher energy (MeV), whereas X-rays are usually in the KeV range. The basic difference between gamma rays and X-rays is their origin; gamma rays are emitted from the nucleus of unstable atoms, while X-rays originate in the electron shells.

The basic difference between gamma rays and visible light is their frequency.

All the transmutation examples given could be accompanied by gamma emission. Although most nuclear decay reactions do have gamma emissions associated with them, there are some radionuclide species which decay by particulate emission with no gamma emission.

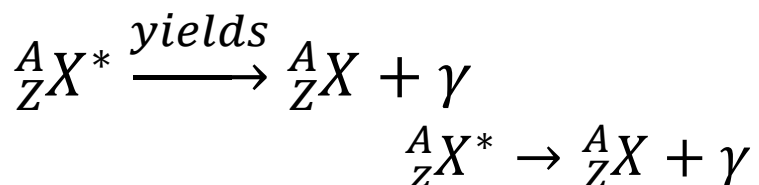

Other Types of Transformations

Internal conversion

This phenomenon occurs when a gamma photon does not escape the electron cloud surrounding the nucleus, but transfers to one of the orbital electrons enough energy to eject it from the atom.

The photon is said to have undergone internal conversion.

The conversion electron is ejected from the atom with kinetic energy equal to the gamma energy minus the binding energy of the orbital electron.

This process usually takes place in the K-shell. There will then follow emission of characteristic X-rays as with electron capture.

In principle, internal conversion is similar to the photoelectric effect

**Standardized RP Junior Task Qualifications Study Guide**  
**Lesson RP01.01 Revision 2**

### Isomeric transition

Isomeric transition commonly occurs immediately after particle emission; however, the nucleus may remain in an excited state for a measurable period before dropping to the ground state at its own characteristic rate.

A nucleus that remains in such an excited state is known as an isomer because it is in a metastable state; that is, it differs in energy and behavior from other nuclei with the same atomic number and mass number.

The metastable or excited state is usually represented by a small m following the mass number, A, in the standard nuclide notation.

For example, Technetium-99m and Technetium- 99 are isomers.  $Tc^{99m}$  will decay  $Tc^{99}$  with the emission of a 140.5 keV gamma.

Generally, the isomer achieves ground state by emitting delayed (usually greater than  $10^{-9}$  seconds) gamma radiation.

Further radioactive decay can still occur from the ground state. In this case,  $Tc^{99}$  decays to  $Ru^{99}$ , which is stable.

### Bremsstrahlung

Bremsstrahlung is the radiative energy loss of moving charged particles as they interact with the matter through which they are moving.

Bremsstrahlung radiation results from the interaction of a high-speed particle near a heavy (high Z) atom. The particle is deflected from its course by the electrostatic force of the positively charged nucleus. The kinetic energy the electron loses is emitted as X-ray radiation.

The photon emitted is an X-ray because it originated outside the nucleus.

Standardized RP Junior Task Qualifications Study Guide  
Lesson RP01.01 Revision 2

EO: 1.09 Describe the processes and characteristics of gamma and x-ray interaction with matter

Photoelectric Effect

1. The photon transfers all its energy to an electron; ejecting the electron from the atom
2. The photon disappears
3. Almost always a "K" shell electron (inner shell - lowest energy level)
4. Generally low energy gamma (eV range)

Compton Scattering

1. Photon transfers a part of its energy to an electron (binding energy + kinetic energy = beta particle + lesser energy photon).
2. The less energetic photon (Compton photon) has its direction of travel changed and may undergo further Compton scatter or photoelectric effect interactions in the absorber
3. Any electrons except "K" shell (outer shells – higher energy levels)
4. Generally, occurs with middle energy gamma (low MeV range)
5. The mechanism of Compton Scattering was first fully explained in 1923 by physicist A. H. Compton. He correctly suggested that the photons could be thought of as carrying a bundle of energy like a billiard ball, and that the resulting angles and energies of the electron and residual photon could be computed using the classical laws of physics i.e. conservation of energy and momentum. This explanation was initially rejected by others because it was felt that photons and other forms of electromagnetic energy were really waves which could not exhibit particle-like properties. Compton received the Nobel Prize in physics in 1927 for this discovery.

Pair Production

1. In an interaction between the electromagnetic field of a high Z number nucleus and a photon - all the energy of the photon is transformed into an electron and a positron (two charged particles) each having some kinetic energy.
2. Very high energy gamma required because a minimum energy is required (1.022 MeV to make the mass of the two particles) in fact, it may take energy

**Standardized RP Junior Task Qualifications Study Guide  
Lesson RP01.01 Revision 2**

levels greater than 2 or 3 MeV and then only a very small part of all interactions will cause pair production.

EO: 1.10 Calculate radioactive decay using exponential equations and appropriate graphs

## The Radioactive Decay Law

1. The activity of any sample of radioactive material decreases or decays at a fixed rate which is a characteristic of that radionuclide.
2. No known physical or chemical agents (such as temperature, pressure, dissolution, or combination) may be made to influence this rate.
3. The rate may be characterized by observing the fraction of activity that remains after successive time intervals.
4. For convenience we choose a fraction that is easy to work with, one-half ( $\frac{1}{2}$ ).
5. In using this fraction, we can observe the decay of a radionuclide with the passing of time. We can observe how long it takes for the activity to be reduced to one half of the activity.
6. This time that is required for the activity present to be reduced to one-half we call the half-life.
7. If successive half-lives are observed, we can see a reduction each time by a fraction of one-half, and the effect will be cumulative.
  - a. One half-life reduces to  $(\frac{1}{2})^1$
  - b. Two half-lives reduce to  $\frac{1}{2} \times \frac{1}{2} = (\frac{1}{2})^2$  or  $\frac{1}{4}$
  - c. Three half-lives will reduce to  $\frac{1}{2} \times \frac{1}{2} \times \frac{1}{2} = (\frac{1}{2})^3$  or  $\frac{1}{8}$ .
8. In the general case the fraction of activity remaining after any number of half-lives will be  $(\frac{1}{2})^n$ , where n is the number of half-lives that have elapsed.
9. To put it still another way, the reduction in activity occurs at an exponential rate, which we have expressed as the power of  $\frac{1}{2}$ .
10. It can be observed that as time passes, radioactive decay occurs at an exponential rate.
  - a. In using the half-life for our time value, we express this exponential function as  $(\frac{1}{2})^n$ .
  - b. Beginning at the instant chosen as the starting point we have 100% of the activity, since no time has elapsed, and the number of half-lives is zero ( $n = 0$ ).
  - c. If we use t to represent time, at this point, then,  $t = 0$ .
11. If we let  $T\frac{1}{2}$  represent the half-life, then, after one half-life,  $t = T\frac{1}{2}$ , and  $n = 1$ . This demonstrates that n represents the ratio of time versus the half-life.

Standardized RP Junior Task Qualifications Study Guide  
Lesson RP01.01 Revision 2

12. Mathematically, this is expressed as:

$$n = \frac{t}{T^{\frac{1}{2}}}$$

Where:

$$\begin{aligned} n &= \text{number of half-lives} \\ t &= \text{time elapsed} \\ T^{\frac{1}{2}} &= \text{half-life} \end{aligned}$$

13. Obviously, the units of  $t$  must be the same as the time units of  $T^{\frac{1}{2}}$  in order to determine the value of  $n$ .

- For example, if the half-life of a certain radionuclide is 10 hours, and we allow 4 hours to elapse, the number of half-lives would be  $4/10 = 0.4$ , or 0.4 half-lives.
- The fraction remaining at that instant where  $t = 4$  hours would be:

$$\left(\frac{1}{2}\right)^{\frac{4}{10}} = \left(\frac{1}{2}\right)^{0.4} = 0.7578$$

14. The activity at the instant where  $t = 0$  is the initial or original activity, represented as  $A_0$ .

15. The activity at any time  $t$  after 0 we will denote as  $A_t$ .

16. The value of  $A_t$  any time  $t$  will be the fraction remaining times  $A_0$ . The fraction remaining is determined from the number of half-lives that have passed.

17. Using a proportion, we can see the relationship between the two activities:

$$\frac{A_0}{A_t} = \frac{1}{\left(\frac{1}{2}\right)^n}$$

18. By cross-multiplying we obtain the equation for determining the remaining activity:

$$A_t = A_0 \left(\frac{1}{2}\right)^n$$

For example, if the initial activity of the radionuclide mentioned above was 52  $\mu\text{Ci}$ , then the activity after 4 hours would be:

$$\begin{aligned} A_t &= 52 \mu\text{Ci} \left(\frac{1}{2}\right)^{\frac{4}{10}} \\ &= 52 \mu\text{Ci}(0.7578) \end{aligned}$$

Standardized RP Junior Task Qualifications Study Guide  
 Lesson RP01.01 Revision 2

$$= 39.4 \mu Ci$$

19. Remember that we stated earlier that radioactive decay is an exponential process. Recall also that a logarithm is, by definition, an exponent.
20. If we were to plot the activity on a logarithmic scale against the time on a linear scale, the resulting curve should be a straight line.
21. This graph shows us that the rate of decay does in fact occur at a constant rate.
22. As time elapses from the starting instant, the activity is reduced thereafter at the constant rate of disintegration for the radionuclide involved, which we represent by the Greek letter  $\lambda$  (pronounced "lambda").
23. The reduction of activity is now a logarithmic (exponential) function of  $(\frac{1}{2})$
24. Since  $n$  is the ratio of  $t$  versus  $T_{\frac{1}{2}}$ , the fraction remaining after time  $t$  will be less than 1, resulting in a negative natural-logarithmic value ( $\ln \frac{1}{2} = -\ln 2 = -0.693$ ).
25. The fraction remaining will be a function of the decay constant ( $\lambda$ ) and the time ( $t$ ).
26. If we then relate the decay constant to the half-life,  $\lambda$  will be a composite of the natural log of 2 and the half-life.
27. Since the process leads to a decrease in activity, the exponent will be represented by  $-\lambda t$ .

28. Therefore, the decay constant itself will represent:

$$\lambda = \frac{\ln 2}{T_{\frac{1}{2}}} = \frac{0.693}{T_{\frac{1}{2}}}$$

29. Thus, the decay constant is the fraction that disintegrates per unit time (reciprocal time).
  - a. If, for example, the half-life is in seconds,  $\lambda$  will be in  $\text{sec}^{-1}$ .
30. The equation for activity using the decay constant will be:

$$A_t = A_o e^{-\lambda t}$$

- a. Note that in this equation the base of the natural log is raised to a power which includes the  $-\ln 2$ .
- b. The result of this equation is exactly the same as that which results from the equation using  $(\frac{1}{2})^n$ .
- c. It is simply a different way of expressing the decrease in activity with the passage of time because of radioactive decay.

Standardized RP Junior Task Qualifications Study Guide  
 Lesson RP01.01 Revision 2

31. Using the data in the prior example, the equation would be:

$$A_t = (52 \mu Ci) e^{-\left(\frac{\ln 2}{10 \text{ hr}}\right) 4 \text{ hr}}$$

$$A_t = (52 \mu Ci) e^{-0.277}$$

$$A_t = (52 \mu Ci)(0.7578)$$

$$A_t = 39.4 \mu Ci$$

32. Example: Given 10 mCi of Phosphor-32, which has a half-life of 14.2 days find the quantity remaining after 60 days.

$$A_t = (10 \text{ mCi}) e^{-\left(\frac{\ln 2}{14.2 \text{ days}}\right) 60 \text{ days}}$$

$$A_t = (10 \text{ mCi}) e^{-0.293}$$

$$A_t = (10 \text{ mCi})(0.0534)$$

$$A_t = 0.534 \text{ mCi}$$

33. By algebraic manipulation other variables in this equation can be solved for if the other values are known.

EO: 1.11 Categorize alpha particles, beta particles, gamma rays and neutrons with respect to mass and energy

1. Alpha particles have a Mass of  $\sim 4$  AMU. Alpha particles are considered monochromatic, due to the energies are nearly the same at  $\sim 5$  MeV Alpha particles are considered monochromatic, due to the energies are nearly the same at  $\sim 5$  MeV
2. Beta particles have a mass  $\ll 1$  AMU. Beta particles exit the nucleus with a continuous distribution of energies between almost zero and a maximum value determined by the available energy for that nuclide. The average value of this distribution for beta minus
3. Gamma rays have no mass. The  $\gamma$  ray energy spectrum is a sharp-line spectrum consisting of definite or discrete energies. The measurements of the energies (typically 0.1 - 2 MeV, however energies  $\gg 5$  MeV are possible) of emitted  $\gamma$  rays serve to locate the nuclear energy levels corresponding to nuclear energy states. The presence of a specific  $\gamma$  energy or energies can be used to detect the presence of a specific radionuclide
4. Neutrons have a mass  $\sim 1$  AMU. Neutrons can be classified according to their energies.
  - a. **Thermal neutrons** (slow neutrons) - energy is approximately 0.025 eV
  - b. **Epithermal neutrons** - intermediate energy: 0.5 eV to 10 keV
  - c. **Fast neutrons** - High energy: 10 keV to 20 MeV
  - d. **Relativistic neutrons** - energies greater than 20 MeV (do not exist in our reactor)

EO: 1.12 Describe the process of neutron activation

## Scattering

A neutron *scattering* reaction occurs when a nucleus, after having been struck by a neutron, emits a single neutron. Even though the initial and final neutrons do not need to be (and often are not) the same, the net effect of the reaction is as if the projectile neutron had merely "bounced off," or scattered from, the nucleus. The two categories of scattering reactions; elastic, and inelastic scattering, are described in the following paragraphs.

### Elastic Scattering

In an *elastic scattering* reaction between a neutron and a target nucleus, there is no energy transferred into nuclear excitation. Momentum and kinetic energy of the "system" are conserved although there is usually some transfer of kinetic energy from the neutron to the target nucleus.

The target nucleus gains the amount of kinetic energy that the neutron loses.

Elastic scattering of neutrons by nuclei can occur in two ways. The more unusual of the two interactions is the absorption of the neutron, forming a compound nucleus, followed by the reemission of a neutron in such a way that the total kinetic energy is conserved, and the nucleus returns to its ground state. This is known as *resonance elastic scattering* and is very dependent upon the initial kinetic energy possessed by the neutron. Due to formation of the compound nucleus, it is also referred to as compound elastic scattering. The second, more usual method is termed *potential elastic scattering* and can be understood by visualizing the neutrons and nuclei to be much like billiard balls with impenetrable surfaces. Potential scattering takes place with incident neutrons that have energy of up to about 1 MeV. In potential scattering, the neutron does not actually touch the nucleus and a compound nucleus is not formed. Instead, the neutron is acted on and scattered by the short-range nuclear forces when it approaches close enough to the nucleus.

### Inelastic Scattering

In *inelastic scattering*, the incident neutron is absorbed by the target nucleus, forming a compound nucleus. The compound nucleus will then emit a neutron of lower kinetic energy which leaves the original nucleus in an excited state. The nucleus will usually, by one or more gamma emissions, emit this excess energy to reach its ground state. For the nucleus that has reached its ground state, the sum of the kinetic energy of the exit neutron, the target nucleus, and the total gamma energy emitted is equal to the initial kinetic energy of the incident neutron.

Standardized RP Junior Task Qualifications Study Guide  
 Lesson RP01.01 Revision 2

### Absorption Reactions

Most *absorption reactions* result in the loss of a neutron coupled with the production of a charged particle or gamma ray. When the product nucleus is radioactive, additional radiation is emitted at some later time. Radiative capture, particle ejection, and fission are all categorized as absorption reactions and are briefly described below.

### Radiative Capture

In *radiative capture* the incident neutron enters the target nucleus forming a compound nucleus. The compound nucleus then decays to its ground state by gamma emission. An example of a radiative capture reaction is shown below.

### Particle Ejection

In a *particle ejection* reaction the incident particle enters the target nucleus forming a compound nucleus. The newly formed compound nucleus has been excited to a high enough energy level to cause it to eject a new particle while the incident neutron remains in the nucleus. After the new particle is ejected, the remaining nucleus may or may not exist in an excited state depending upon the mass-energy balance of the reaction. An example of a particle ejection reaction is shown below.

The flux of neutrons and protons in a nuclear reactor core region leads to several important nuclear reactions with the constituent atoms of water. Most of these reactions involve oxygen isotopes and fast neutrons or protons.

In many cases, the absorption of a fast neutron by a nucleus is immediately followed by ejection of a proton. These reactions are called neutron-proton or n-p reactions and are commonly written (using the  $^{16}\text{O}$  reaction to illustrate) in the following manner.

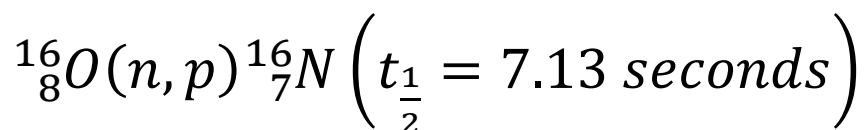

In this notation, the original isotope that undergoes the reaction is written first, the product isotope is last, and the two are separated by, in order, the particle absorbed and the particle emitted. The isotope  $^{16}\text{N}_7$  decays to  $^{16}\text{O}_8$  with a 7.13-second half-life by emitting a beta particle

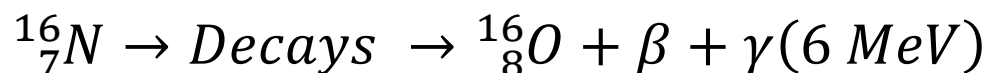

Oxygen-17 undergoes a similar reaction.

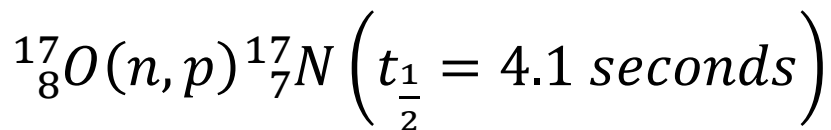

The isotope N decays by emission of a beta particle, a neutron, and a gamma ray.

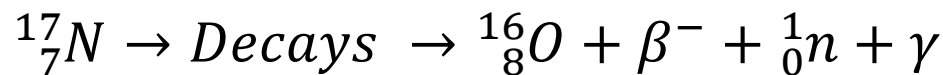

The reactions above have no significant chemical effect on reactor coolant because of the relatively small number of atoms that undergo these reactions. They are of considerable importance, however, because the radioactive species  ${}^{16}\text{N}$  and  ${}^{17}\text{N}$  are carried outside the core region by the flow of reactor coolant. The neutrons and high-energy gamma rays emitted by these isotopes easily penetrate the piping and components that contain the coolant and are important considerations in the design of shielding for nuclear facilities. Because the half-lives of these isotopes are very short, they decay to low levels very rapidly after shutdown and are, therefore, of little concern during such periods.

Two other nuclear reactions with oxygen isotopes are shown below.

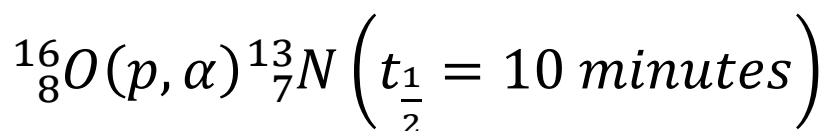
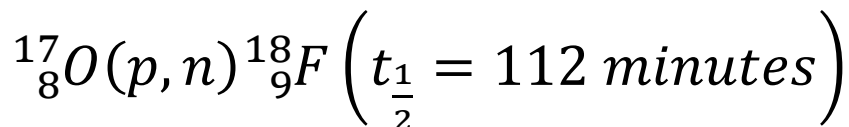

An ejected alpha particle is indicated by  $\alpha$ . The protons that cause these reactions result from inelastic collisions of fast neutrons with hydrogen atoms in water molecules. The radioactivity levels of these isotopes are much lower than the levels of  ${}^{16}\text{N}$  and  ${}^{17}\text{N}$  during reactor facility operation. However, during the period from a few minutes to about five hours after reactor shutdown or after removing a coolant sample from the system,  ${}^{13}\text{N}$  and  ${}^{18}\text{F}$  are the principal sources of radioactivity in the reactor coolant of most reactor facilities.



Standardized RP Junior Task Qualifications Study Guide  
Lesson RP01.01 Revision 2

The only significant nuclear reaction that occurs with hydrogen involves deuterium ( $^2\text{H}$ ), which comprises about 0.015 percent of natural hydrogen.

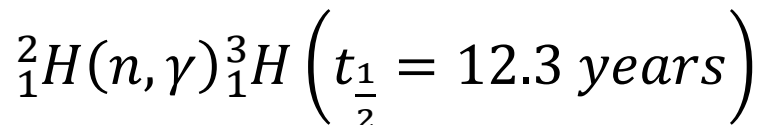

Tritium ( $^3\text{H}$ ) decays by emission of a very weak particle (0.02 Mev) and no gamma rays.

Thus, tritium is not a radiological hazard unless it enters the body in significant amounts.

Tritium can enter the body through inhalation or ingestion. It is also possible to absorb forms of tritium through the skin.

EO: 1.13 List major sources of natural background radiation including cosmic radiation, uranium and thorium decay chains, potassium 40, and radon gas (including daughter products).

### Sources of Radiation

We live in a radioactive world and always have. In fact, the majority of us will be exposed to more ionizing radiation from natural background radiation than from our jobs.

#### 1) Natural sources

- a. There are several sources of radiation that occur naturally. The radiation emitted from these sources is identical to the radiation that results from manmade sources. The four major sources of naturally occurring radiation exposures are:
  - Cosmic radiation
  - Sources in the earth's crust, also referred to as terrestrial radiation
  - Sources in the human body, also referred to as internal sources
  - Radon
  - i. Cosmic radiation (total average dose ~ 28 mrem/yr)
    1. Cosmic radiation comes from the sun and outer space. It consists of positively charged particles and gamma radiation.
    2. At sea level, the average annual cosmic radiation dose is about 26 mrem.
    3. At higher elevations, the amount of atmosphere shielding cosmic rays decreases; therefore, the dose increases.
- b. Sources in earth's crust (terrestrial) (total average dose ~ 28 mrem/yr)
  - i. There are natural sources of radiation in the ground (i.e., rocks and soil).
    1. Some of the contributors to terrestrial sources are the natural radioactive elements radium, uranium, and thorium.
    2. Many areas have elevated levels of terrestrial radiation due to increased concentrations of uranium or thorium in the soil.
- c. Internal (total average dose ~40 mrem/yr)
  - i. The food we eat and the water we drink contain trace amounts of natural radioactive materials.
  - ii. These naturally occurring radioactive materials deposit in our bodies and cause internal exposure to radiation.
  - iii. Some naturally occurring radioactive isotopes include Sodium-24 (Na-24), Carbon-14 (C-14), Argon-41 (Ar-41), and Potassium-40 (K-40). Most of our internal exposure comes from K-40.
- d. Radon (total average dose ~ 200 mrem/yr)

- i. Radon comes from the radioactive decay of uranium, which is naturally present in the soil.
- ii. Radon is a gas. It can travel through the soil and enter through building foundation cracks. The greatest concentrations of indoor radon are found in basements.
- iii. Radon emits alpha radiation. It presents a hazard only when taken into the body (e.g., when inhaled).

### Total Background Radiation

The average annual total effective dose to the general population (nonsmokers) from naturally occurring and manmade sources is about 620 mrem.

Standardized RP Junior Task Qualifications Study Guide  
Lesson RP01.01 Revision 2

EO: 1.14 Identify specific isotopes of concern in power reactors during operation and following shutdown

Individuals working at a nuclear power plant may be exposed to radiation emitted from radionuclides created because of nuclear reactor operation. A radionuclide is an atom with an unstable nucleus. Its nucleus is unstable because it has excess energy to give away, either to a newly created radiation particle inside of the nucleus or to an electron orbiting the nucleus. When this happens, the radionuclide undergoes radioactive decay, and emits a radiation particle or gamma ray. These particles or rays, if they have sufficient energy, make up ionizing radiation.

Radionuclides may occur naturally but can also be artificially produced. These radionuclides are transported throughout the plant by the reactor coolant system and auxiliary systems.

Radionuclides are present in the reactor coolant system because of two processes: neutron activation and fission product leakage.

The first process is the neutron activation of corrosion, impurities, chemicals, and the water contained in the reactor coolant system. Metal components that make up the reactor coolant system corrode, and the corrosion products accumulate in the core where they are exposed to a high neutron flux and become activated. Neutron activation is a physical reaction where a stable atom receives an additional neutron and becomes unstable (radioactive).

Some common radionuclides are cobalt, iron, chromium, manganese, copper, zinc, nickel, zirconium, nitrogen, fluoride, oxygen, cesium, rubidium, strontium, iodine, krypton, and xenon. This activated corrosion material is known as “CRUD”. CRUD in the core is eventually released and makes its way to various locations in the reactor coolant system and systems that interface with the reactor coolant system. Likewise, chemical impurities, chemical additives, and the reactor coolant water itself can become activated and contribute to radiation in the plant

The idea that crud was an acronym came from a 1959 article by Commander E.E. Kintner.

In 1953, Kintner headed the Advanced Design Group under Hyman Rickover developing the Mark I prototype reactor for the first nuclear powered submarine, the Nautilus. To verify that the reactor’s fuel elements would not corrode, Kintner recalled, samples were placed in a research reactor located at Chalk River, Canada. After several months of irradiation, the fuel elements were covered in deposits—Chalk River Unidentified Deposits. This was worrisome since the deposits might block the flow of coolant around the fuel causing them to overheat

**Standardized RP Junior Task Qualifications Study Guide**  
**Lesson RP01.01 Revision 2**

and melt. While the problem was resolved by adjusting water chemistry, "CRUD" lived on as an acronym for radioactive deposits."

The second is fission product leakage through small defects in the reactor fuel rods. Fuel rods are sealed to contain fission products; however, minor defects do develop and some fission products leak from the fuel into the reactor coolant system. This radioactive material is transferred from the fuel to other parts of the plant via the reactor coolant system, reactor coolant cleanup systems, heat exchangers, and vents, leaks, and drains from these systems.

A percentage of reactor coolant is continuously being taken from the reactor coolant system for removal or cleanup of radioactive material. Since these cleanup systems now contain reactor coolant water, which is radioactive, the cleanup systems are a source of radiation exposure. Liquid and gaseous waste disposal systems, or subsystems of the cleanup system, are additional transport paths for radioactive material

As water in the reactor coolant, reactor coolant cleanup, and waste disposal systems flows through heat exchangers, the heat exchangers become a source of radiation exposure to personnel. Vents and drains on these

systems transport radioactive material to other plant areas, as do unplanned leaks in system lines and components.

Activated corrosion products (CRUD) and fission products are often deposited in low flow areas (e.g., dead legs, valves, bends in pipes) of systems containing radioactive liquids. As the radioactivity in these "crud traps" accumulates with time, the exposure rates increase resulting in "hot spots".

Plant systems and components that are sources of radiation exposure include:

- Spent reactor fuel.
- Reactor vessel.
- Reactor coolant system.
- Reactor coolant purification system (including filters and demineralizers).
- Radioactive liquid waste processing systems (including tanks, filters, demineralizers, and evaporators).
- Radioactive gas waste processing systems (including tanks, compressors, charcoal bed absorbers, and filters).
- Inside Containment Building (Reactor Building) during power operations.

Standardized RP Junior Task Qualifications Study Guide  
Lesson RP01.01 Revision 2

To help maintain worker's exposures to as low as is reasonably achievable (ALARA), most systems containing radioactive material are located within shielded cubicles, or personnel access to the areas is controlled. The annual average radiation exposure to nuclear plant workers is less than 1000 mrem

Another potential source of exposure in the plant is exposure to radiography sources. Radiography is a non-destructive testing technique used to inspect welds, piping, and other components. A high energy gamma source is used to take photographs (similar to x-rays) of the components. Radiography accidents and overexposures are common to industries where this technique is employed (including the nuclear industry). For instance, a 100 Ci Ir-192 source will generate a dose of about 50 rem/hr at one meter. The on-contact dose rate on the shielded camera would be around 30 – 40 mrem/hr. Great caution should be used whenever radiography is taking place.

All metallic surfaces of the plant, in contact with coolant, will oxidize or corrode to some extent to form metal oxides. A small portion of these oxides will either go into solution ions or be deposited on system surfaces as insoluble matter. These metal oxides are referred to as **CRUD**.

**CRUD** is undesirable for two reasons.

1. Deposits throughout the system will increase general radiation levels. (Particularly important during maintenance outages due to ALARA concerns).
2. CRUD will also cause the fouling of the core heat transfer surfaces. Some common corrosion product activations are:

<u>Radionuclide</u>	<u>Shorthand Production Reaction</u>	<u>Longhand Production Reaction</u>
Cr-51	$^{50}_{Cr}(n_{th}, \gamma)^{51}_{Cr}$	$^{50}_{24}Cr + n_{th} \rightarrow ^{51}_{24}Cr + \gamma$
Fe-59	$^{58}_{Fe}(n_{th}, \gamma)^{59}_{Fe}$	$^{58}_{26}Fe + n_{th} \rightarrow ^{59}_{26}Fe + \gamma$
Mn-56	$^{55}_{Mn}(n_{th}, \gamma)^{56}_{Mn}$	$^{55}_{25}Mn + n_{th} \rightarrow ^{56}_{25}Mn + \gamma$
Co-58	$^{58}_{Ni}(n_f, p)^{58}_{Co}$	$^{58}_{28}Ni + n_f \rightarrow ^{58}_{27}Co + p$

Standardized RP Junior Task Qualifications Study Guide  
Lesson RP01.01 Revision 2

**Activation of Trace Impurities in Water** - Several nuclides are available in trace amounts in the reactor coolant and will enter the core where they become activated.

Common activated impurities are:

<u>Radionuclide</u>	<u>Production Reaction</u>	<u>Origin</u>
H-3	${}^6_{Li}(n, \alpha){}^3_H$	Lithium addition for pH control
Na-24	${}^{23}_{Na}(n, \gamma){}^{24}_{Na}$	Impurity in Water
Ar-41	${}^{40}_{Ar}(n, \gamma){}^{41}_{Ar}$	Air dissolved in water

**Activation of Water** - Several nuclides are produced from the activation of the water of the RCS itself, recall from previous objective.

The common nuclides from the activation of water are:

<u>Radionuclide</u>	<u>Production Reaction</u>	<u>Origin</u>
N-16	${}^{16}_8O(n, p){}^{16}_7N$	Water molecule
N-17	${}^{17}_8O(n, p){}^{17}_7N$	Water molecule
F-18	${}^{17}_8O(p, n){}^{18}_9F$	Water molecule
N-13	${}^{16}_8O(p, \alpha){}^{13}_7N$	Water molecule

**Transuranics**

Transuranic refers to any element with an atomic number greater than that of uranium. The transuranic nuclides are produced from neutron capture reactions of  ${}^{238}U$  and other transuranic nuclides in the fuel. Since these are heavy nuclei, a large number of these radionuclides are fissionable and/or alpha emitters.

Transuranic include the following:

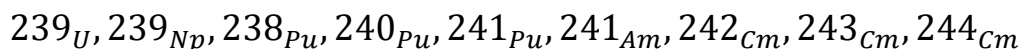

Transuranics are formed as the result of neutron capture and several sequential decays, such as:

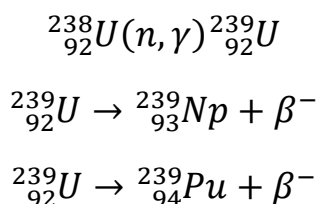

Standardized RP Junior Task Qualifications Study Guide  
Lesson RP01.01 Revision 2

EO: 1.15 Describe radon decay as related to daughters and physical properties

Natural Decay Chains

[http://metadata.berkeley.edu/nuclear-](http://metadata.berkeley.edu/nuclear-forensics/Decay%20Chains.html)

[forensics/Decay%20Chains.html](http://metadata.berkeley.edu/nuclear-forensics/Decay%20Chains.html) Example of a reactor produced decay chain:

Equation for the fission of  $U^{235}$  with selected fission products

The equation demonstrating the nuclear reaction for the fission process is written generically as:

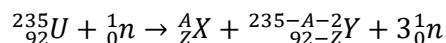

Note that the number of nucleons is conserved in this reaction.

Using this generic statement, any fission fragments may be used in place of the X and Y fragments shown. The number of nucleons in the reaction, however, must always remain the same.

The equation for the thermal fission of  ${}^{235}U$  to produce  ${}^{100}Mo$  and  ${}^{133}Sn$  may be used as an example:

1. The first half of the equation remains the same.

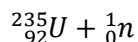

${}_{92}^{235}U$  absorbs a thermal neutron (which may also be indicated by  ${}_0^1n_{th}$ ).

2. In the second half of the equation, the products must be shown.

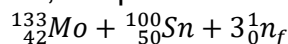

Note that the total number of nucleons started with was 236 (with 92 of them being protons). The sums of those in the products must be the same number.

1. The overall reaction may be written as:

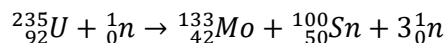

Standardized RP Junior Task Qualifications Study Guide  
Lesson RP01.01 Revision 2

EO: 1.16 Identify and use radiological quantities and their units including activity (curies and becquerels), exposure (roentgens), dose (rads and grays), and dose equivalent (rems and sieverts)

**Curie (Ci)** - One of three units used to measure the intensity of radioactivity in a sample of material. This value refers to the amount of ionizing radiation released when an element (such as uranium) spontaneously emits energy as a result of the radioactive decay (or disintegration) of an unstable atom.  $2.2 \times 10^{12}$  disintegrations per minute (dpm) or  $3.7 \times 10^{10}$  disintegrations per second (dps)

**Becquerels (Bq)** - One of three units used to measure [radioactivity](#), which refers to the amount of [ionizing radiation](#) released when an [element](#) (such as [uranium](#)) spontaneously emits energy as a result of the [radioactive decay](#) (or disintegration) of an unstable [atom](#). Radioactivity is also the term used to describe the rate at which radioactive material emits radiation, or how many atoms in the material decay (or disintegrate) in a given time period. As such, 1 Bq represents a rate of radioactive decay equal to 1 disintegration per second, and 37 billion ( $3.7 \times 10^{10}$ ) Bq equals 1 [curie \(Ci\)](#).

**Roentgens (R)** - A unit of exposure to ionizing radiation. It is the amount of gamma or x-rays required to produce ions resulting in a charge of 0.000258 coulombs/kilogram of air under standard conditions. Named after Wilhelm Roentgen, the German scientist who discovered x-rays in 1895.

**Rad** - (radiation absorbed dose) One of the two units used to measure the amount of radiation absorbed by an object or person, known as the "[absorbed dose](#)," which reflects the amount of energy that radioactive sources deposit in materials through which they pass. The radiation absorbed dose (rad) is the amount of energy (from any type of [ionizing radiation](#)) deposited in any medium (e.g., water, tissue, air). An absorbed dose of 1 rad means that 1 gram of material absorbed 100 ergs of energy (a small but measurable amount) because of exposure to radiation. The related international system unit is the [gray \(Gy\)](#), where 1 Gy is equivalent to 100 rad. For additional information, see [Doses in Our Daily Lives](#) and [Measuring Radiation](#).

**Gray** - One of the two units used to measure the amount of radiation absorbed by an object or person, known as the "[absorbed dose](#)," which reflects the amount of energy that radioactive sources (with any type of [ionizing radiation](#)) deposit in materials (e.g., water,

Standardized RP Junior Task Qualifications Study Guide  
Lesson RP01.01 Revision 2

tissue, air) through which they pass. One gray (Gy) is the international system of units (SI) equivalent of 100 [rads](#), which is equal to an absorbed dose of 1 Joule/kilogram. An absorbed dose of 0.01 Gy means that 1 gram of material absorbed 100 ergs of energy (a small but measurable amount) as a result of exposure to radiation. For additional information, see [Doses in Our Daily Lives](#) and [Measuring Radiation](#).

**Rem** - One of the two standard units used to measure the [dose equivalent](#) (or effective dose), which combines the amount of energy (from any type of [ionizing radiation](#) that is deposited in human tissue), along with the medical effects of the given type of radiation. For [beta](#) and [gamma](#) radiation, the dose equivalent is the same as the [absorbed dose](#). By contrast, the dose equivalent is larger than the absorbed dose for [alpha](#) and [neutron](#) radiation, because these types of radiation are more damaging to the human body. Thus, the dose equivalent (in rems) is equal to the absorbed dose (in [rads](#)) multiplied by the [quality factor](#) of the type of radiation [see Title 10, Section 20.1004, of the *Code of Federal Regulations* ([10 CFR 20.1004](#)), "Units of Radiation

Dose"]. The related international system unit is the [sievert \(Sv\)](#), where 100 rem is equivalent to 1 Sv. For additional information, see [Doses in Our Daily Lives](#) and [Measuring Radiation](#)

**Sievert** - The international system (SI) unit for dose equivalent equal to 1 Joule/kilogram. 1 sievert = 100 rem. Named for physicist Rolf Sievert

The related international system unit is the [sievert \(Sv\)](#), where 100 rem is equivalent to 1 Sv. For additional information, see [Doses in Our Daily Lives](#) and [Measuring Radiation](#)

Standardized RP Junior Task Qualifications Study Guide  
Lesson RP01.01 Revision 2

EO: 1.17 Identify and use significant dose terms including deep dose equivalent, eye (lens) dose equivalent, shallow dose equivalent, effective dose equivalent, committed dose equivalent, committed effective dose equivalent, total effective dose equivalent, and total organ dose equivalent

**Deep Dose Equivalent (DDE)** – Whole body dose equivalent at a tissue depth of 1 cm (1,000 mg/cm<sup>2</sup>)

**Eye Dose Equivalent** – Applies to the external exposure of the lens of the eye, is the dose equivalent at a tissue depth of 300 mg/cm<sup>2</sup> (0.3cm)

**Shallow Dose Equivalent (SDE)** - The external exposure of the skin or an extremity taken at a tissue depth of 0.007 cm (7 mg/cm<sup>2</sup>)

**Effective Dose Equivalent (EDE)** - The sum of the products of the tissue or organ weighting factors from 10CFR20, and the dose to the corresponding body tissues and organs resulting from the exposure to radiation sources external to the body.

**Committed Dose Equivalent (CDE) (HT, 50)** - The dose equivalent to organs or tissues of reference (T) that will be received from an intake of radioactive material by an individual during the 50-year period following the intake

**Total Effective Dose Equivalent (TEDE)** - The sum of the deep dose equivalent (external exposure) and the committed effective dose equivalent (internal exposure).

**Committed effective dose equivalent (CEDE)** , As defined in Title 10, Section 20.1003, of the *Code of Federal Regulations* ([10 CFR 20.1003](#)), the CEDE ( $H_{E,50}$ ) is the sum of the products of the [committed dose equivalents](#) for each of the body organs or tissues that are [irradiated](#) multiplied by the weighting factors ( $W_T$ ) applicable to each of those organs or tissues ( $H_{E,50} = \sum W_T H_{T,50}$ ).

**Total organ dose equivalent (TODE)** is also included in the 2015 updated forms to denote the sum of the deep-dose equivalent (DDE) and the committed dose equivalent (CDE) to the organ receiving the highest dose, to be consistent with the regulations described in 10 CFR

20.2106(a)(6).1 Although this regulation does not include the acronym TODE, the acronym is used by NRC staff to denote “total organ dose equivalent.”

EO: 1.18 Convert radioactivity to dose rate through simple rules of thumb and associated calculation for various source geometries

To use the basic methods for controlling exposure, the worker must be able to determine the intensity of the radiation fields. The following equations are used to make this determination.

1. A "rule-of-thumb" method to determine the radiation field intensity for simple sources of radioactive material is the "curie/meter/rem" rule. (Co-60)
  - a. Ci @ 1 meter = 1 R/hr
2. To determine the gamma radiation field intensity for a radioactive point source

$$I_{1FT} = 6CEN$$

where:

$I_{1ft}$  = Exposure rate in R/hr 1 ft.

C = Activity of the source in Ci

E = The gamma energy in MeV

N = The number of gammas per disintegration

- i This equation is accurate to within  $\pm 20\%$  for gamma energies between 0.05 MeV and 3 MeV.
  - ii If N is not given, assume 100% photon yield (1.00 photons/disintegration).
  - iii If more than one photon energy is given, take the sum of each photon multiplied by its percentage, i.e.:
    - iv  $[(\gamma 1)(\%1) + (\gamma 2)(\%2) + \dots + (\gamma n)(\%n)]$
3. For distances in meters:

$$I_{1m} = 0.5CEN$$

4. For short distances greater than 1 foot from the source, the inverse square law can be applied with reference to the dose rate at 1 foot, resulting in the following equation:
5. For short distances greater than 1 foot from the source, the inverse square law can be applied with reference to the dose rate at 1 foot, resulting in the following equation:

Standardized RP Junior Task Qualifications Study Guide  
Lesson RP01.01 Revision 2

$$a = \frac{(6CEN)(1^2)}{d^2}$$

6. For metric distances the equation becomes:

$$a = \frac{(0.5CEN)(1^2)}{d^2}$$

where: d = distance in feet

7. Example: Determine the exposure rate at 10 ft for a 8 Ci point source of Co<sup>60</sup> that emits a 1.173 and 1.332 MeV gamma, both at 100% of the disintegrations.

$$I = \frac{(6CEN)(1^2)}{d^2}$$

$$I = \frac{\left(6(8Ci)(1.173MeV) \left(1 \frac{\gamma}{dis}\right)\right)}{10^2} = 0.563$$

$$I = \frac{\left(6(8Ci)(1.332MeV) \left(1 \frac{\gamma}{dis}\right)\right)}{10^2} = 0.639$$

$$I = 0.563 + 0.639 = 1.2 \frac{R}{hr}$$

8. Example: To determine the exposure rate at 1 ft for a 1Ci point source of Cs that emits a 662 keV (0.662 MeV) gamma in 85% of the disintegrations.

$$I = \frac{(6CEN)(1^2)}{d^2}$$

$$I = \frac{\left(6(1Ci)(0.662 MeV) \left(\frac{0.85\gamma}{dis}\right)\right) (1^2)}{1^2} = 3.38 \frac{R}{hr}$$

9. Example: Calculate the exposure rate at 2 meters for a 1.8 Ci point source of <sup>60</sup>Co that emits two gammas (1.173 MeV and 1.332 MeV) for every disintegration.

$$I = \frac{(0.5CEN)(1^2)}{d^2}$$

$$I = \frac{\left(0.5(1.8 \text{ Ci})(1.173 \text{ MeV})\left(\frac{1\gamma}{\text{dis}}\right)\right)(1^2)}{2^2} = 0.264 \text{ R/hr}$$

$$I = \frac{\left(0.5(1.8 \text{ Ci})(1.332 \text{ MeV})\left(\frac{1\gamma}{\text{dis}}\right)\right)(1^2)}{2^2} = 0.300 \text{ R/hr}$$

$$I = 0.264 + 0.300 = 0.564 \frac{R}{\text{Hr}} @ 2 \text{ meters}$$

10. Example: Calculate the exposure rate at 1 ft., for a 400-mCi <sup>192</sup>Ir which emits the following gammas: 0.316 MeV (87%), 0.486 MeV (52%), 0.308 MeV (32%), 0.295 MeV (30%).

$$I = \frac{(6CEN)(1^2)}{d^2}$$

$$I = \frac{\left(6(0.400)(0.316 \text{ MeV})\left(\frac{0.87\gamma}{\text{dis}}\right)\right)(1^2)}{1^2} = 0.66 \frac{R}{\text{hr}}$$

$$I = \frac{\left(6(0.400)(0.486 \text{ MeV})\left(\frac{0.52\gamma}{\text{dis}}\right)\right)(1^2)}{1^2}$$

$$= 0.607 \frac{R}{\text{hr}}$$

$$I = \frac{\left(6(0.400)(0.308\text{MeV})\left(\frac{0.32\gamma}{dis}\right)\right)(1^2)}{1^2}$$

$$= 0.237 \frac{R}{hr}$$

$$I = \frac{\left(6(0.400)(0.295\text{MeV})\left(\frac{0.30\gamma}{dis}\right)\right)(1^2)}{1^2}$$

$$= 0.212 \frac{R}{hr}$$

$$I = 0.66 + 0.607 + 0.237 + 0.212 = 1.716 \frac{R}{hr}$$

EO: 1.19 Select the processes and characteristics of neutron interaction with matter including elastic scattering, inelastic scattering, absorption, neutron activation, and fission

Neutron Interactions

Classified by:

1. Kinetic energy of the neutron (recall from objective 1.4)
  - a. Thermal: ( $< 0.5$  eV)
  - b. Intermediate: (0.5 eV - 100 keV)
  - c. Fast: (100 keV - 20 MeV)
  - d. Relativistic: ( $> 20$  MeV)
2. Absorption cross section of target
  - a. Some elements absorb neutrons more readily than others i.e., cadmium, boron, and hafnium
3. Slow Neutron Interactions (Capture)
  - a. Radiative Capture: neutron is absorbed into nucleus and a gamma is emitted.  
This is also called gamma emission or neutron activation.  
Charged Particle Emission: neutron is absorbed into nucleus and a charged particle is emitted
    - a. Fission: neutron is absorbed into nucleus then the nucleus splits into fission fragments.
2. Fast Neutron Interactions (Scatter)
  - a. Elastic Scattering: kinetic energy is the only form of energy involved.

- b. Inelastic Scattering: some kinetic energy is changed to Scattering" excitation energy of the nucleus which then emits a photon (gamma ray) to remove this excitation energy.
3. Remember neutrons are not charged particles but neutron interactions do produce charged particles and photons, which will cause large amounts of secondary ionization and excitation

EO: 1.20 Select the types of materials for shielding each type of radiation

Shielding design is relatively straightforward depending upon the type of radiation (gamma, neutron, alpha, beta). For example, when considering the reactor core, it is first necessary to slow down the fast neutrons (those not directly absorbed) coming from the core to thermal energy by utilizing appropriate neutron attenuating shielding materials that are properly arranged. This slowing down process is mostly caused by collisions that slow the neutrons to thermal energy. The thermal neutrons are then absorbed by the shielding material. All of the gamma rays in the system, both the gamma rays leaving the core and the gamma rays produced by neutron interactions within the shielding material have to be attenuated to appropriate levels by utilizing gamma ray shielding materials that are also properly arranged. The design of these radiation shields and those used to attenuate radiation from any radioactive source depend upon the location, the intensity, and the energy distribution of the radiation sources, and the permissible radiation levels at positions away from these sources. In this chapter, we will discuss the materials used to attenuate neutron, gamma, beta, and alpha radiation.

### Neutron Radiation

The shielding of neutrons introduces many complications because of the wide range of energy that must be considered. At low energies (less than 0.1 MeV), low mass number materials, such as hydrogen in H<sub>2</sub>O, are best for slowing down neutrons. At these energies, the cross section for interaction with hydrogen is high (approximately 20 barns), and the energy loss in a collision is high. Materials containing hydrogen are known as hydrogenous material, and their value as a neutron shield is determined by their hydrogen content. Water ranks high and is probably the best neutron shield material with the advantage of low cost, although it is a poor absorber of gamma radiation.

Water also provides a ready means for removing the heat generated by radiation absorption. At higher energies (10 MeV), the cross section for interaction with hydrogen (1 barn) is not as effective in slowing down neutrons. To offset this decrease in cross section with increased neutron energy, materials with good inelastic scattering properties, such as iron, are used. These materials cause a large change in neutron energy after collision for high energy neutrons but have little effect on neutrons at lower energy, below 0.1 MeV.

Iron, as carbon steel or stainless steel, has been commonly used as the material for thermal shields. Such shields can absorb a considerable proportion of the energy of fast

**Standardized RP Junior Task Qualifications Study Guide**  
**Lesson RP01.01 Revision 2**

neutrons and gamma rays escaping from the reactor core. By making shields composed of iron and water, it is possible to utilize the properties of both of these materials. PWRs utilize two or three layers of steel with water between them as a very effective shield for both neutrons and gamma rays. The interaction (inelastic scattering) of high energy neutrons occurs mostly with iron, which degrades the neutron to a much lower energy, where the water is more effective for slowing down (elastic scattering) neutrons. Once the neutron is slowed down to thermal energy, it diffuses through the shield medium for a small distance and is captured by the shielding material, resulting in a neutron, gamma (n, g) reaction. These gamma rays represent a secondary source of radiation.

Iron turnings or punchings and iron oxide have been incorporated into heavy concrete for shielding purposes also. Concrete with seven weight percent or greater of water appears to be adequate for neutron attenuation. However, an increase in the water content has the disadvantage of decreasing both the density and structural strength of ordinary concrete. With heavy concretes, a given amount of attenuation of both neutrons and gamma rays can be achieved by means of a thinner shield than is possible with ordinary concrete. Various kinds of heavy concretes used for shielding include barytes concrete, iron concrete, and ferrophosphorus concrete with various modified concretes and related mixtures. Boron compounds (for example, the mineral colemanite) have also been added to concretes to increase the probability of neutron capture without high energy gamma-ray production.

Boron has been included as a neutron absorber in various materials in addition to concrete. For example, borated graphite, a mixture of elemental boron and graphite, has been used in fast reactor shields. Boral, consisting of boron carbide (B<sub>4</sub>C) and aluminum, and epoxy resins and resin-impregnated wood laminates incorporating boron have been used for local shielding purposes. Boron has also been added to steel for shield structures to reduce secondary gamma ray production. In special situations, where a shield has consisted of a heavy metal and water, it has been beneficial to add a soluble boron compound to the water.

### Gamma Radiation

Gamma radiation is the most difficult to shield against and, therefore, presents the biggest problem in the reactor plant. The penetrating power of the gamma is due, in part, to the fact that it has no charge or mass. Therefore, it does not interact as frequently as do the other types of radiation per given material.

Gamma rays are attenuated by processes which are functions of atomic number and mass (that is they all involve interactions near the nucleus or interactions with the electrons around the nucleus). Gamma shielding is therefore more effectively performed by materials with high atomic mass number and high density. One such material is lead.

**Standardized RP Junior Task Qualifications Study Guide**  
**Lesson RP01.01 Revision 2**

Lead is dense and has about 82 electrons for each nucleus. Thus, a gamma would interact more times in passing through eight inches of lead than passing through the same thickness of a lighter material, such as water. As the gamma interacts with the shielding material, it loses energy and eventually disappears. Lead and lead alloys have been used to some extent in nuclear reactor shields and have an added advantage of ease of fabrication. Because of its low melting point, lead can be used only where the temperatures do not exceed its melting point.

Iron, although a medium weight element, also functions well as a gamma attenuator. For gamma rays with energies of 2 MeV, roughly the same mass of iron as of lead is required to remove a specific fraction of the radiation. At higher and lower energies, however, the mass-attenuation efficiency of lead is appreciably greater than that of iron. In many cases, the selection of iron is based on structural, temperature, and economic considerations.

Water is a poor material for shielding gamma rays; however, large amounts will serve to attenuate gamma radiation.

Concrete, as discussed previously, is also a good attenuator of gamma rays and is superior to water. This is mainly a result of the presence of moderately high mass number elements, such as calcium and silicon. As a general shield material, there is much to recommend about concrete; it is strong, inexpensive, and adaptable to both block and monolithic types of construction.

### Alpha and Beta Radiation

Alpha particles, being the largest particles of radiation and having a +2 charge, interact with matter more readily than other types of radiation. Each interaction results in a loss of energy. Therefore, the alpha has the shortest range of all the types of radiation. Alpha particles generally are stopped by a thin sheet of paper. As a comparison, a 4 MeV alpha particle will travel about 1 inch in air, whereas a 4 MeV beta particle will travel about 630 inches in air. Because it deposits all its energy in a very small area, the alpha particle travels only a short distance.

The beta particle is more penetrating than the alpha. However, because of the -1 charge, the beta particle interacts more readily than a non-charged particle. For this reason, it is less penetrating than uncharged types of radiation such as the gamma or neutron. The beta particle can generally be stopped by a sheet of aluminum. Because the beta travels farther than the alpha, it deposits its energy over a greater area and is, therefore, less harmful than the alpha if taken internally. All materials described under neutron and gamma radiation are also effective at attenuating beta radiation.

Since alpha and beta particles can be easily shielded against, they do not present a major problem in the nuclear reactor plant during normal plant operations however during outage and maintenance activities these become a concern.



EO: 1.21 Define buildup factor

The buildup factor is defined as follows: in the passage of radiation through a medium, the ratio of the total value of a specified radiation quantity at any point to the contribution to that value from radiation reaching the point without having undergone a collision.

or...

The ratio of the total photons at a point to the number arriving there without being scattered.

In thick shielding you must account for buildup factor which is due to the scattering of radiation in the absorber

Standardized RP Junior Task Qualifications Study Guide  
 Lesson RP01.01 Revision 2

EO: 1.22 Recall values of Half or Tenth Value Layer (HVL/TVL) for Cobalt-60 gamma rays for lead, steel, concrete and water.

The recognition of the character of the  $\alpha$  and  $\beta$  rays as streams of high-speed particles came largely because of magnetic and electrostatic deflection experiments. In this way, the  $\beta$  rays were seen to be electrons moving at nearly the velocity of light. At first, the paths of the  $\alpha$  rays were thought to be unaffected by these fields. More refined experiments did show deflections, from which the ratio of charge to mass was calculated to be about half that of the hydrogen ion, with the charge positive, and the velocity was calculated to be about one tenth that of light. The suggestion that  $\alpha$  particles were helium ions was immediately made, and it was confirmed after much more study. The presence of helium in uranium and thorium ores had already been noticed and was seen to be significant in this connection. A striking demonstration was later made, in which  $\alpha$  rays were allowed to pass through a very thin glass wall into an evacuated glass vessel; within a few days sufficient helium gas appeared in the vessel to be detected spectroscopically.

Before the completion of these studies of the  $\alpha$  and  $\beta$  rays, an even more penetrating radiation not deviated by a magnetic field, was found in the rays from radioactive preparations. The recognition of this gamma radiation as electromagnetic waves, like X-rays in character if not in energy, came rather soon. For a long time no distinction was made between the nuclear gamma rays and some extra-nuclear X-rays that often accompany radioactive transformation.

Shielding Calculations

The simplest method for determining the effectiveness of the shielding material is using the concepts of half-value layers (HVL) and tenth-value layers (TVL).

One half-value layer is defined as the amount of shielding material required to reduce the radiation intensity to one-half of the unshielded value.

$$\text{HVL} = \ln 2 / \mu = 0.693 / \mu$$

One tenth-value layer is defined as the amount of shielding material required to reduce the radiation intensity to one-tenth of the unshielded value.

$$\text{TVL} = \ln(10) / \mu = 2.3026 / \mu$$

Standardized RP Junior Task Qualifications Study Guide  
 Lesson RP01.01 Revision 2

Both of these concepts are dependent on the energy of the photon radiation and a chart can be constructed to show the HVL and TVL values for photon energies.

The basic calculational approach to photon shielding is to determine the existing exposure rate, decide on the desired exposure rate after shielding and then calculate how many HVL or TVL will be needed.

The basic equation for using the HVL concept is:

$$I = I_0 (1/2)^n$$

Where :

I = final dose rate

$I_0$  = initial dose rate  $n$  = #HVL =  
 shield thickness (cm)/HVL (cm)

The basic equation for using the TVL concept is:

$$I = I_0 (1/10)^n$$

Where :

I = final dose rate

$I_0$  = initial dose rate  $n$  = #TVL =  
 shield thickness (cm)/TVL (cm)

Calculate the shielded exposure rate from a 500 mR/hr Cs-137 source with 5 cm of lead shielding. The HVL for Cs-137 and lead is 0.65 cm.

$$I = I_0 (1/2)^n$$

$$n = \# \text{ HVL} = 5 \text{ cm} / 0.65 \text{ cm} = 7.7 \text{ HVL}$$

$$I = 500 \text{ mR/hr} (1/2)^{7.7} = 2.4 \text{ mR/hr}$$

Calculate the shielded exposure rate from a 7.4 R/hr Cs-137 source with 4 cm of lead shielding. The HVL for Cs-137 and lead is 0.65 cm.

Standardized RP Junior Task Qualifications Study Guide  
Lesson RP01.01 Revision 2

$$I = I_0 (1/2)^n$$

$$n = \# \text{ HVL} = 4 \text{ cm} / 0.65 \text{ cm} = 6.15 \text{ HVL}$$

$$I = 7.4 \text{ R/hr} (1/2)^{6.15} = 0.104 \text{ R/hr} = 104 \text{ mR/hr}$$

Calculate the #TVL and the thickness of lead required to reduce the exposure rate from a 7.5R/hr Co-60 source to less than 100 mR/hr. One TVL for Co-60 and lead is 4.0 cm.

$$I = I_0 (1/10)^n$$

$$n = \# \text{ TVL} = 4 \text{ cm} / ? = ? \text{ TVL}$$

$$100 \text{ mR/hr} = 7.5 \text{ R/hr} (1/10)^n \quad \text{Log} (100/7500) = \text{log} (1/10)^n \quad n = 1.87 \text{ TVL} = 4 \text{ cm} / ? = 7.5 \text{ cm}$$

Calculate the #TVL and the thickness of lead required to reduce the exposure rate from a 450 mR/hr Co-60 source to less than 5 mR/hr.

One TVL for Co-60 and lead is 4.0 cm.

$$I = I_0 (1/10)^n$$

$$n = \# \text{ TVL} = 4 \text{ cm} / ? = ? \text{ TVL}$$

$$5 \text{ mR/hr} = 450 \text{ mR/hr} (1/10)^n \quad \text{Log} (5/450) = \text{log} (1/10)^n \quad n = 1.95 \text{ TVL} = 4 \text{ cm} / ? = 7.8 \text{ cm}$$

Standardized RP Junior Task Qualifications Study Guide  
Lesson RP01.01 Revision 2

rule of thumb HVL for Co-60

lead= 0.49"

Steel= 0.85"

Concrete = 2.38"

Water = 10"

TVL CO-60

lead = 1.57"

steel= 2.71"

concrete= 8"

water= 24"

EO: 1.23 Describe the phenomenon of "sky shine".

Gamma ray shielding design needs to account for sky shine. "Sky Shine" is radiation reflected to earth by the atmosphere. The air does provide a medium to scatter gamma rays. Sky shine, appears to come from the sky, in fact it is generated when large gamma sources are not shielded properly above the source. The name reflects the fact that gamma rays appear to shine down from the sky if adequate shielding is not placed above the source.

A classic example is movement and storage of highly radioactive resins. Sky shine can occur and generate radiation areas long distances from the source. Typically, during storage these items have shielding above the resin to prevent sky shine.

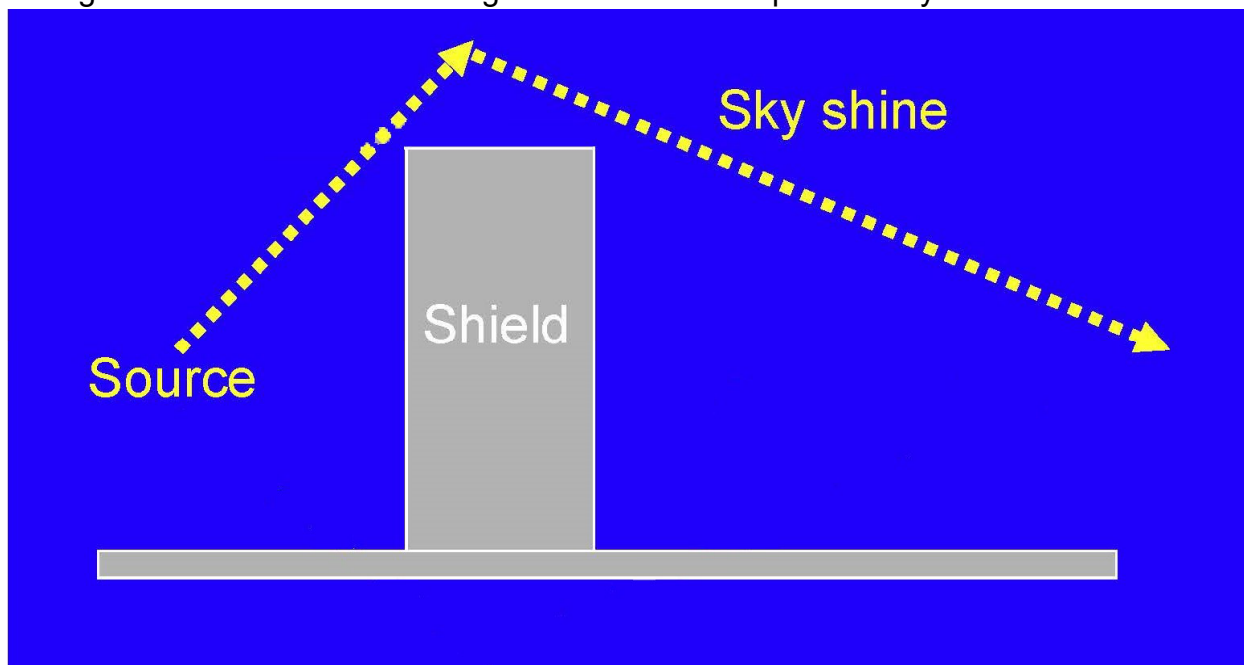

Standardized RP Junior Task Qualifications Study Guide  
 Lesson RP01.01 Revision 2

EO: 1.24 Apply quality factors for converting dose to dose equivalent

10CFR20.104

Units of Radiation Dose definition of Quality Factor - The dose equivalent in rems is equal to the absorbed dose in rads multiplied by the quality factor.

Table 1004(b).1 Quality Factors and Absorbed Dose Equivalencies

Type of radiation	Quality Factor	Absorbed dose equal to a unit dose equivalent <sup>a</sup>
	(Q)	
X-ray, gamma, or beta radiation	1	1
Alpha particles, multiple charged particles, fission fragments and heavy particles of unknown charge	20	0.05
Neutrons of unknown energy	10	0.1
High Energy protons	10	0.1

<sup>a</sup> Absorbed dose in rad equal to 1 rem or the absorbed dose in gray equal to 1 sievert.

EO: 1.25 Describe the mechanisms of radiation interactions with cells

### Effects of Radiation on Cells

The human body is made up of many organ systems. Each system is made up of tissues. Specialized cells make up tissues. Ionizing radiation can potentially affect the normal function of cells.

1. Biological effects begin with the ionization of atoms
  - a. The method by which radiation causes damage to human cells is by ionization of atoms in the cells. It may also cause excitation. Excitation is where the radiation deposits energy into an atom raising its energy level but not enough energy to eject a bound electron. Atoms make up the cells that make up the tissues of the body. Any potential radiation damage begins with damage to atoms.
  - b. A cell is made up of two principal parts, the body of the cell and the nucleus. The nucleus is like the brain of the cell.
  - c. When ionizing radiation hits a cell, it may strike a vital part of the cell like the nucleus or a less vital part of the cell, like the cytoplasm.

### Radiation Damage to Cell Constituents

1. Cell Membrane
  - a. It takes about 3,000 - 5,000 rad (30 - 50 gray) to rupture.
  - b. Results in leakage of beneficial material and introduction of potentially harmful fluids.
  - c. At lower doses, radiation increases the permeability, and some leakage occurs.
2. Cytoplasm
  - a. Negligible effect
3. Mitochondria
  - a. A "few thousand" rad will disrupt the function.
  - b. Interrupts the storage of energy via Adenosine Tri-Phosphate (ATP).
  - c. If the cell has a large reserve of stored food, it can repair itself.
  - d. The greater the dose, the greater the damage, the longer the repair time.
  - e. If the repair time is too long and the food reserve fails, the cell dies from starvation.
4. Lysosome
  - a. Ruptures between 500 and 1,000 rad (5 - 10 gray)
  - b. Digestive enzymes are released and begin to digest the rest of the cell.

Standardized RP Junior Task Qualifications Study Guide  
Lesson RP01.01 Revision 2

5. Nucleus

- a. Difficult to affix a dose because the nucleus is the most radiosensitive part of the cell.
- b. Inhibits the ability of the cell to divide by affecting the DNA and RNA.
- c. Without normal DNA the cell cannot produce a duplicate set of chromosomes.
- d. The longer division is delayed the greater chance it will die; as the dose increases, the delay time lengthens.
- e.

Primary and Secondary Effects of Radiation

1. Primary Effect

- a. Ionization & Excitation of atoms making up the cell.
- b. Produced when the primary (initial) interaction of radiation is with the target atoms in the cell such as those in the DNA.

2. Secondary Effects

- a. Formation of free radicals which are very reactive and can chemically attack target molecules, such as DNA.
- b. Occurs with the disassociation of water.
- c. Water makes up 70 - 80% of the cell.
  - i. Three possible reactions:
    1.  $H^+$  interacting with  $H = H_2$
    2.  $OH^-$  combining with  $H = H_2O$
    3.  $H_2 + OH^- = H_2O_2$
- d. Formation of  $H_2O_2$  (hydrogen peroxide) can lead to cell death.  $H_2O_2$  is a harmful oxidizer which poisons the cell

EO: 1.26 Identify cell characteristics that affect radiosensitivity

Cell sensitivity

Some cells are more sensitive than others to environmental factors such as viruses, toxins, and ionizing radiation.

1. Actively dividing and non-specialized cells.
  - a. Cells in our bodies that are actively dividing are more sensitive to ionizing radiation.
  - b. Cells that are rapidly dividing include blood-forming cells, the cells that line our intestinal tract, hair follicles, and cells that form sperm.
2. Less actively dividing and more specialized cells.
  - a. Cells that divide at a slower rate or are more specialized (such as brain cells or muscle cells) are not as sensitive to damage by ionizing radiation.

Possible effects of radiation on cells

Several things can happen when a cell is exposed to ionizing radiation. The following are possible effects of radiation on cells.

1. There is no damage
2. Cells are damaged but can repair the damage and operate normally.
  - a. The body of most cells is made up primarily of water. When ionizing radiation hits a cell, it is most likely to interact with the water in the cell. One of the byproducts of radiation-induced ionization of water is hydrogen peroxide. Hydrogen peroxide can damage cell atomic structures.
  - b. Ionizing radiation can also hit the nucleus of the cell. The nucleus contains the vital parts of the cell, such as chromosomes. The chromosomes determine cell function. When chromosomes duplicate themselves, the chromosomes transfer their information to new cells. Radiation may cause a change in the chromosome that does not affect the cell.
  - c. Damage to chromosomes and other cell structures can be repaired. In fact, our bodies repair a very large number of chromosome breaks.
3. Cells are damaged and operate abnormally.

- a. Cell damage may not be repaired or may be incompletely repaired. In that case, the cell may not be able to function properly.
  - b. It is possible that a chromosome in the cell nucleus could be damaged but not be repaired correctly. If the cell continues to reproduce, this is called a mutation and may result in cancer.
4. Cells die because of the damage.
- a. At any given moment, thousands of our cells die and are replaced by normal functioning cells. However, the radiation damage to a cell may be so extensive that the cell dies prematurely.

Standardized RP Junior Task Qualifications Study Guide  
Lesson RP01.01 Revision 2

Radio-sensitivity

The relative susceptibility of cells, tissues and organisms to the injurious action of radiation

1. Law of Bergonie and Tribondeau (1906):
  - a. "The radio-sensitivity of a tissue is directly proportional to its reproductive capacity and inversely proportional to its degree of differentiation".
  - b. Factors which affect a cells sensitivity to radiation.
  - c. Cells are more sensitive if they have a high division rate.
  - d. The higher the metabolic rate in a cell, the lower its resistance to radiation.
  - e. Cells tend to be more sensitive if they are non-specialized.
  - f. Well-nourished cells, or cells with a high level of oxygenation are more sensitive.
2. Radiosensitive Tissues:
  - a. Germinal (reproductive) cells of the ovary and testis e.g., spermatogonia.
  - b. Hematopoietic (blood forming) tissues: red bone marrow, spleen, lymph nodes, thymus.
  - c. Basal cells of the skin.
  - d. Epithelium of the gastrointestinal tract (interstitial crypt cells).
3. Radio-resistant Tissues:
  - a. Bone
  - b. Liver
  - c. Kidney
  - d. Cartilage
  - e. Muscle
  - f. Nervous tissue
4. Radio-sensitivity not only differs from one cell or tissue to another but also between individuals and genders

Note: They do not follow the four general rules, A whole body exposure of 600 - 700 R will kill most animals; however, even higher doses have been delivered to the brain for cancer treatment.

EO: 1.27 Define stochastic and non-stochastic effects

**Standardized RP Junior Task Qualifications Study Guide**  
**Lesson RP01.01 Revision 2**

**Stochastic effects.** Effects that occur by chance, generally occurring without a threshold level of dose, whose probability is proportional to the dose and whose severity is independent of the dose. In the context of radiation protection, the main **stochastic** effects are cancer and genetic effects.

**Non-stochastic effect.** The health effects of radiation, the severity of which vary with the dose and for which a threshold is believed to exist. Radiation-induced cataract formation is an example of a non-**stochastic** effect (also called a deterministic effect) (see 10 CFR 20.1003).

**Stochastic and Deterministic Effects**

1. Stochastic Effects

- a. An effect in which the probability of the effect occurring increases with the dose.
- b. The effects have no established threshold, they can occur from the irradiation of only one cell; any exposure, however low, has some chance of causing the effect.
- c. Two examples of stochastic effects: cancer and genetic mutations.

2. Deterministic (Non-Stochastic) Effects

- a. Effects in which the severity of the effect increases as the dose increases
- b. It is generally assumed that a threshold exists; and if doses received are below the threshold dose, no effects will occur
- c. Effects typically result from the collective injury of many cells

Effects include cataracts, skin burns, lowering of blood cell counts, etc.

EO: 1.28 Compare and contrast between acute and chronic radiation exposure, and for each, describe the somatic effects, genetic effects, and teratogenic effects

### Effects of Chronic Exposures to Ionizing Radiation

1. Chronic exposure
  - a. Typically refers to smaller exposures over a long time period
  - b. No unique disease associated with radiation exposure, but there is a statistical increase in the risk of developing disease
  - c. Radium dial painters, early radiologists, atomic bomb survivors provide evidence of induced effects in humans.
    - i Radium dial painters used their tongues to shape their paint brush, early radiologists were exposed to RAD after RAD daily for years and that bomb blast survivors may have received doses of hundreds of Rem and were exposed to Alpha, Beta, Gamma and neutron radiation.
2. Cancer (Somatic)
  - a. Radiation induced cancers are justification for today's protection standards
  - b. Possibility of inducing tumors
  - c. Radiation may cause cancer but also be used to treat can be use to heal cancer (by a surgeon) or to inflict injury.
3. Cataracts
  - a. A cataract is opacity of the lens of the eye
  - b. A chronic exposure of 600 rad (6 gray) may produce a cataract for high LET radiation
  - c. Generally, symptoms will not appear for years after the exposure
  - d. Effects may be cumulative
  - e. Neutrons and gamma are primary hazards
  - f. Exposures at younger ages increase susceptibility
4. Life Span (Shortening or Lengthening)
  - a. Data is uncertain and firm conclusions are difficult to estimate.
  - b. Aging is the progressive deterioration of tissues along with declining functional capacities

- c. Irradiated animals under lab conditions showed some cellular changes that can be associated with aging

### **Effects of Acute Radiation Exposures**

Acute exposures are those exposures which involve relatively large doses of radiation received over a relatively short period of time.

1. Stages
  - a. Prodromal
  - b. Latent
  - c. Illness
  - d. Recovery/death
2. Three syndromes
  - a. Hematopoietic Syndrome
    - i. Also called "Therapeutic Range" because treatment can play a large role
    - ii. Dose level - Between 200 to 1,000 rads (2 -10 gray) - (Some blood changes can be seen at lower doses)
    - iii. Critical organs are the blood forming organs
    - iv. Affects the production of white blood cells -Leukopenia- decreased ability to fight infection
    - v. Lowered platelet count causes hemorrhaging and slowing of the healing process
    - vi. Symptoms:
      1. Nausea and vomiting
      2. Epilation
    - vii. Treatment - antibiotics to fight infection  
bone marrow transplants to replace damaged cells, (uncertain if this works)
    - viii. If death does occur it will be due to infection and hemorrhaging
  - b. Gastrointestinal Syndrome
    - i. Dose level - Between 1,000 - 5,000 rads (10 -50 gray)
    - ii. Affects the GI tract
    - iii. Stops the production of new epithelial cells which line the wall of the intestines and are responsible for absorption of nutrients and control body fluid metabolism.
    - iv. Symptoms:
      1. appear in a few hours
      2. nausea and vomiting
      3. dehydration from diarrhea and low nutrient absorption
      4. electrolyte imbalance
      5. Cause of death: circulatory collapse from loss of fluids

Standardized RP Junior Task Qualifications Study Guide  
Lesson RP01.01 Revision 2

- c. Central Nervous System (CNS) Syndrome
  - i. Dose level: >5,000 rad (>50 gray)
  - ii. Critical Organ: Central Nervous System
  - iii. Symptoms:
    - 1. Convulsions
    - 2. tremors
    - 3. ataxia
    - 4. lethargy
    - iv. Cause of death
    - 5. Respiratory failure and/or brain edema
- d. In the event an individual survives an acute exposure of high dose, they run an increased risk of latent effects

EO: 1.29 Describe the purpose and basic content of 10 CFR 20, "Standards for Protection Against Radiation".

The regulations in this part establish standards for protection against ionizing radiation resulting from activities conducted under licenses issued by the Nuclear Regulatory Commission. These regulations are issued under the Atomic Energy Act of 1954, as amended, and the Energy Reorganization Act of 1974, as amended.

It is the purpose of the regulations in this part to control the receipt, possession, use, transfer, and disposal of licensed material by any licensee in such a manner that the total dose to an individual (including doses resulting from licensed and unlicensed radioactive material and from radiation sources other than background radiation) does not exceed the standards for protection against radiation prescribed in the regulations in this part. However, nothing in this part shall be construed as limiting actions that may be necessary to protect health and safety.

Standardized RP Junior Task Qualifications Study Guide  
Lesson RP01.01 Revision 2

EO: 1.30 For acute exposures, describe the dose response relationship, acute radiation syndrome, LD-50/30, and LD-50/60

High whole body dose rates: o ~20 Rem: The first signs of blood changes may be seen. (Chromosomal Aberration)

Hematopoietic Syndrome – occurs between 70-1000 rad (0.7-10 Gy), affects the blood forming tissue

Affects the production of white blood cells - decreased ability to fight infection

- Lowered platelet count causes hemorrhaging and slowing of healing
- Symptoms – Nausea and vomiting, epilation
- Treatment – antibiotics and bone marrow transplants
- If death occurs – from infection and hemorrhaging

Gastrointestinal Syndrome – Occurs 1000 (10 Gy) rad, affects the GI tract o Stops the production of new cells which line the wall of the intestines that are responsible for:

- absorption of nutrients and
- control body fluid metabolism.
  - o Symptoms: nausea and vomiting, dehydration from diarrhea and low nutrient absorption, electrolyte imbalance
  - o If death occurs: circulatory collapse

Central Nervous System (CNS) Syndrome- Greater than 5000 rad (50 Gy), affects the CNS

- Symptoms – convulsions, tremors, ataxia, lethargy
- If death occurs respiratory failure and/or brain edema

Reference. <https://emergency.cdc.gov/radiation/arsphysicianfactsheet.asp>

The required conditions for Acute Radiation Syndrome (ARS) are:

The radiation dose must be large (i.e., greater than 0.7 Gray (Gy) or 70 rads.

- Mild symptoms may be observed with doses as low as 0.3 Gy or 30 rads.

The dose usually must be external ( i.e., the source of radiation is outside of the patient's body).

- Radioactive materials deposited inside the body have produced some ARS effects only in extremely rare cases.

The radiation must be penetrating (i.e., able to reach the internal organs).

- High energy X-rays, gamma rays, and neutrons are penetrating radiations

### Standardized RP Junior Task Qualifications Study Guide Lesson RP01.01 Revision 2

The entire body (or a significant portion of it) must have received the dose>.

- Most radiation injuries are local, frequently involving the hands, and these local injuries seldom cause classical signs of ARS.

The dose must have been delivered in a short time (usually a matter of minutes).

- Fractionated doses are often used in radiation therapy. These are large total doses delivered in small daily amounts over a period. Fractionated doses are less effective at inducing ARS than a single dose of the same magnitude.

LD 50/30, the portion (50%) of the general population expected to receive a lethal dose and die in a 30 period without medical care the population, 400 – 500 rad.

LD50/60, 50% of the population expected to die in a 60-day period in 60 days without medical care– 200 – 300 rad.

EO: 1.31 Explain the concepts and objectives of an ALARA TEDE evaluation.

The site-specific radiological control manual should establish trigger levels requiring formal radiological review of non-routine or complex work activities. The trigger levels should be based on radiological conditions in existence or expected prior to implementation of the job-specific engineering and administrative controls.

These appropriate trigger levels should include:

- Estimated individual or collective dose greater than pre-established values (e.g., any individual likely to receive a dose exceeding 50% of the local administrative control level or collective dose likely to exceed 1 man-rem)
- Predicted airborne radioactivity concentrations in excess of pre-established values
- Removable contamination on accessible surfaces greater than pre-established values
- Entry into areas where dose rates exceed 1 rem/hour
- Potential releases of radioactive material to the environment.

EO: 1.32 Explain the basis for and implications of the linear zero-threshold dose- response curve

The theory that radiation protection standards are based upon is called the Linear Non-Threshold (LNT).

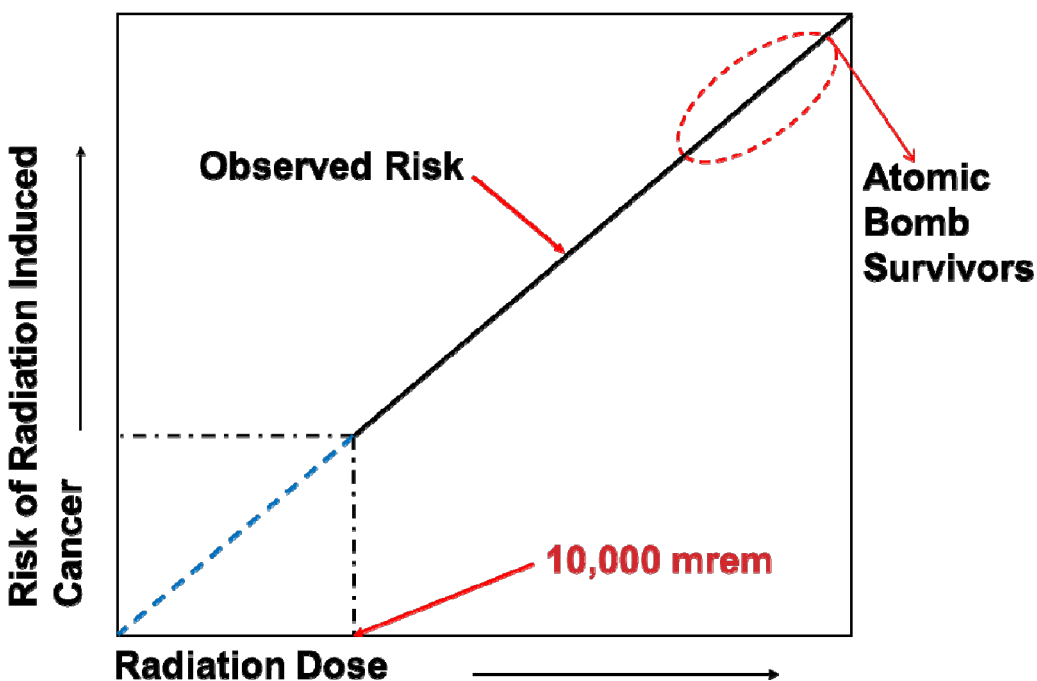

In part, because of the difficulties in determining if the health effects that are demonstrated at high radiation doses are also present at low doses. It is assumed that these effects are produced in direct proportion to the dose received, e.g. doubling the radiation dose results in a doubling of the effect. These two assumptions lead to a dose-response relationship, often referred to as the linear, no-threshold model, for estimating health effects at radiation dose levels of interest. There is, however, substantial scientific evidence that this model is an oversimplification.

The most reliable studies of the effects of radiation exposure at the low levels received by occupational workers have not been able to detect adverse health effects associated with lifetime exposures smaller than approximately 0.1 Sv. (0.1 Sv = 10,000 mrem)

The linear no-threshold theory uses these observed effects at very high doses and extrapolates the risk through the zero point on the graph. The largest cohort of individuals

**Standardized RP Junior Task Qualifications Study Guide**  
**Lesson RP01.01 Revision 2**

with a high radiation exposure is the atomic bomb survivors. This group also has been studied extensively since 1945.

- Reference Radiation Risk In Perspective, Health Physics Society, PS010-2
- Occupational Radiation Safety Standards and Regulations are Sound, Health Physics Society, PS013-01

EO: 1.33 Explain why radiation exposures to both individuals and groups of workers should be kept ALARA

**As Low As Reasonably Achievable**

As applied to occupational radiation exposure, the ALARA process does not require that exposures to radiological hazards be minimized without further consideration, but that such exposures be optimized, considering both the benefits arising out of the activity and the detriments arising from the resultant radiation exposures and the controls to be implemented.

An effective ALARA process includes effective consideration, planning, and implementation of both physical design features (including engineering controls) and administrative controls to balance the risks of occupational radiation exposure against the benefits arising out of the authorized activity. Lessons learned are documented, institutionalized, and considered in planning and executing subsequent activities to further the goals of the ALARA process and to provide optimal employee protection.

Standardized RP Junior Task Qualifications Study Guide  
Lesson RP01.01 Revision 2

EO: 1.34 Explain the risk to a pregnant worker and fetus

**Effects on the Embryo/Fetus**

1. According to the law of Bergonie and Tribondeau, children are more radiosensitive than adults, fetuses more than children, and embryos are the most radiosensitive.
2. Radiation doses may cause death or abnormalities.
3. Most critical period 2 to 6 weeks gestation – most organs formed
4. Doses as low as 25 rad (0.25 gray) may cause defects.
5. Reported effects include blindness, cataracts, mental deficiency, coordination defects, deformed arms legs, and general mental/physical sub normality
6. An exposure of 400 - 600 rad (4 - 6 gray) during the first trimester (excluding the first week) of pregnancy is sufficient to cause fetal death and spontaneous abortion

**Prenatal Radiation Exposure**

Although no effects were seen in Japanese children conceived after the atomic bomb, there were effects seen in some children who were in the womb when exposed to the atomic bomb radiation at Hiroshima and Nagasaki. Some of these children were born with a slightly smaller head size, lower average birth weight, and increased incidence of mental retardation. Some later showed lower IQ test scores and slower scholastic development, smaller physical size, and increased incidence of behavioral problems.

1. Sensitivity of the fetus

Embryo/fetal cells are rapidly dividing, which makes them sensitive to many environmental factors including ionizing radiation. The embryo/fetus is most susceptible to developing adverse health effects if exposed during the time period of 8 - 15 weeks after conception.

2. Factors for potential effects associated with prenatal exposures.

Many chemical and physical (environmental) factors are suspected of causing or known to have caused damage to a fetus, especially early in the pregnancy. Radiation, alcohol consumption, exposure to lead, and heat, such as from hot tubs, are only a few such factors.

Standardized RP Junior Task Qualifications Study Guide  
Lesson RP01.01 Revision 2

EO: 1.35 Explain the purpose of radiation protection limits regarding risk and effect minimization.

All RP limits set forth by the NRC, are deemed acceptable risk. Acceptable risk assumes there is a benefit for an individual receiving dose. In a power plant that benefit is generation of power. All radiation protection limits are set to limit stochastic effects. Limits set to prevent non-stochastic effects are the ALI, TODE, VHRA. All of these limits have the potential to cause immediate effects from radiation exposure.

10 CFR 20, paragraph 20.1(c) states, “. . . persons engaged in activities under licenses issued by the NRC . . . should, in addition to complying with the requirements set forth in this part, make every reasonable effort to maintain radiation doses, and releases of radioactive effluents to unrestricted areas, as low as is reasonably achievable. The term ‘as low as is reasonably achievable’ means as low as is reasonably achievable considering the state of technology, and the economics of improvements in relation to benefits to the public health and safety, and other societal and socioeconomic considerations, and in relation to the utilization of atomic energy in the public interest. “

Regulatory Guide 8.8 - The guide states that effective implementation of an ALARA philosophy involves:

1. Establishment of a program to maintain exposures ALARA.
2. Consideration of exposure impacts in the design of facilities and selection of equipment.
3. Establishment of a radiation control program that includes plans and procedures for controlling exposures.
4. Providing supporting equipment, instrumentation, and facilities.

The key to ALARA is reasonable. What is the cost associated with saving 1 Rem of exposure?

Companies may set the cost dose, based on insurance rates as, potentially \$20,000 per collective rem depending upon the Stations INPO collective radiation exposure (CRE).

Part of the assessment is saving dose reasonable is this quantification. For example, if a station would like to install shielding at a cost of \$60,000, but the shielding is going to save 1 REM CRE, that station will not be able to justify this cost. However, if the station installation of shielding would save 4 rem, the cost is justifiable.

Standardized RP Junior Task Qualifications Study Guide  
Lesson RP01.01 Revision 2

EO: 1.36 Describe the principles of operation and characteristics of the types of dosimetry used at a plant, including the range(s) of each device, advantages of each type of device, limitations of each type of device, and radiofrequency interference

Types of legal dosimeter you typically find in nuclear power plants are either thermoluminescent dosimeter (TLD) or optically stimulated luminescent dosimeter (OSLD). Both detectors give off visible light when processed. The energy absorbed from radiation is stored in a crystalline material. The difference is that the TLD requires heat to luminesce (give off light) which is then used to determine dose. The OSLD uses visible light during processing to luminesce. The major disadvantage of TLDs is that the dosimeter cannot be re-read after processing.

OSL principles of operation:

Measures radiation using aluminum oxide crystal detectors also known as OSL material. Electrons in the crystal that have been excited by ionizing radiation jump to the conduction band and are trapped in imperfections. They are released when stimulated by light. Because of the material, this released energy results in the emission of light.

Read out process uses green light from either a laser or light emitting diode (LED) array to stimulate the detectors. The resulting blue light emitted by the OSL material is detected and measured by a photomultiplier tube using a high sensitivity photon counting system.

A measurement is made of the light intensity released. The light that is released is directly proportional to incident radiation and is used to perform a dose calculation. Shielding of the crystals allows differentiation of types of radiation.

Advantages of OSLDs:

1. Faster and more accurate reading.
2. Allows for multiple readings to confirm reported doses. TLDs can only be read once, so the results cannot be confirmed or if the data is lost, it cannot be re-read.

Less “fading” than TLDs

In addition, to dosimeters of legal record as described above secondary dosimeters are utilized called electronic personnel dosimeters. These electronic devices can read both dose and dose rates for gamma, beta, and neutron radiation. Electronic dosimetry is susceptible to electronic interference. This is commonly seen during welding operations. Electronic dosimetry may be available that is shielded to this electronic interference. Typically, these devices can have the following ranges (varies for each device):

**Standardized RP Junior Task Qualifications Study Guide  
Lesson RP01.01 Revision 2**

Dose 0 – 1000 rem

Dose rate: 0 – 2000 rem/hr

EO: 1.37 Describe the dosimetry used at a plant to determine doses from various types of radiation including gamma whole-body dose, gamma extremity dose, beta skin dose, neutron dose, and lens of eye dose

### **TYPES OF DOSIMETRY**

- 1) As a result of irradiation, some solid substances undergo changes in some of their physical properties.
- 2) These changes amount to storage of the energy from the radiation.
- 3) Since the energy is stored, these materials can be used for dosimeters. The features that have been studied include:
  - a) Optical density changes
    - i) Optical density changes involve a change in the color of some types of plastics and glass.
    - ii) In glass, the dose range is  $10^3$  to  $10^6$  rads (10 to  $10^4$  gray). The range for plastics is  $10^6$  to  $10^9$  rads ( $10^4$  to  $10^7$  gray).
    - iii) An example, film badges, provides low range, 10 mR to 10 R, for personnel and high range, 1 R to 1,000 R for accident readings.
  - b) Thermoluminescence
    - i) Thermoluminescence (TL) is the ability of some materials to convert the energy from radiation to a radiation of a different wavelength, normally in the visible light range. ii) There are two categories of thermoluminescence.
      - (1) Fluorescence - This is emission of light during or immediately after irradiation (within fractions of a second) of the phosphor. This is not a particularly useful reaction for TLD use.
      - (2) Phosphorescence - This is the emission of light after the irradiation period. The delay time can be from a few seconds to weeks or months. This is the principle of operation used for thermoluminescent dosimeters.
    - iii) The property of thermoluminescence of some materials is the main method used for personnel dosimeters at DOE facilities and will be discussed in further detail.

### **TLD OPERATION**

- 1) TLD's use phosphorescence as their means of detection of radiation.
- 2) Electrons in some solids can exist in two energy states, called the valence band and the conduction band. The difference between the two bands is called the band gap.
- 3) Electrons in the conduction band or in the band gap have more energy than the valence band electrons.

Standardized RP Junior Task Qualifications Study Guide

Lesson RP01.01 Revision 2

- 4) Normally in a solid, no electrons exist in energy states contained in the band gap. This is a "forbidden region."
- 5) In some materials, or if impurities are added, defects in the material exist or are made that can trap electrons in the band gap and hold them there. These trapped electrons represent stored energy for the time that the electrons are held. This energy is given up if the electron returns to the valence band.
- 6) In most materials, this energy is given up as heat in the surrounding material, however, in some materials a portion of energy is emitted as light photons. This property is called luminescence.

**TLD Reader**

- 1) Basic principle of operation
  - a) Heating of the TL material causes the trapped electrons to return to the valence band. When this happens, energy is emitted in the form of visible light.
  - b) The light output is detected and measured by a photomultiplier tube and a dose is then calculated.
  - c) A typical basic TLD reader contains the following components:
    - i) Heater
    - ii) Photomultiplier tube
    - iii) Meter/recorder
- 2) Glow curve
  - a) Obtained from heating process.
  - b) The light output from TL material is not easily interpreted. Multiple peaks result.
    - i) As the material is heated, electrons trapped in "shallow" traps are released. This results in a peak as these traps are emptied. The light output drops off as these traps are depleted.
    - ii) As heating continues, the electrons in deeper traps are released. This results in additional peaks. Usually the highest peak is used for calculations. The area under the curve represents the radiation energy deposited.
    - iii) After the readout is complete, the TLD is annealed at a high temperature. This process essentially zeroes the TL material by releasing all trapped electrons. The TLD is then ready for reuse.

**ADVANTAGES AND DISADVANTAGES OF TLDs**

- 1) Advantages (primarily as compared to film badges)
  - a) Able to measure a greater range of doses.
  - b) Doses may be easily obtained.
  - c) They can be read on site instead of being sent away for developing.
  - d) Quicker turnaround time for readout.
  - e) Reusable.
- 2) Disadvantages
  - a) Each dose cannot be read out more than once.
  - b) The readout process effectively "zeroes" the TLD.

Standardized RP Junior Task Qualifications Study Guide  
Lesson RP01.01 Revision 2

**POCKET AND ELECTRONIC DOSIMETERS**

- 1) Provide real time dose indication
- 2) Shall be issued for entry into High or Very High Radiation Area.
- 3) Should be issued when planned activity levels exceed 0.05 rem (0.0005 sievert) or 10% of control levels.
- 4) Should be issued when required by RWP.
- 5) Worn with primary dosimetry and located on chest area, on or between the waist and the neck.
- 6) Should be read periodically and should not exceed 75% of full scale.
- 7) Authorized work should cease when supplemental dosimeter indicates total dose or dose rate is > than expected.
- 8) When supplemental dosimeters differ by more than 50% from primary dosimeters and the primary result is >0.1 rem sievert), an investigation should be initiated.

**SITE SELF-READING DOSIMETERS**

- 1) Self-Reading Pocket Dosimeters (SRPD)
  - a) Direct reading ion chamber.
  - b) Utilizes two electrodes:
    - i) Fiber electrometer (fixed and moveable components)
    - ii) Metal frame
  - c) As chamber is ionized the charge is decreased on the movable and fixed fiber.
  - d) The movement of the fiber is proportional to the dose received.

Standardized RP Junior Task Qualifications Study Guide  
Lesson RP01.01 Revision 2

EO: 1.38 Explain the use of effective dose equivalent monitoring, including weighting factors and limitations in the process

From Reg Guide 8.4, METHODS FOR MEASURING EFFECTIVE DOSE EQUIVALENT FROM EXTERNAL EXPOSURE

To implementing workplace controls, and because of the difference in dosimetry methods, 10 CFR Part 20 breaks the TEDE into two components: (1) dose resulting from radioactive sources internal to the body and (2) dose resulting from radioactive sources external to the body. The doses from external and internal exposures are determined independently by measurement or by calculation and then summed to obtain the TEDE. Several requirements in 10 CFR Part 20 (such as the dose limits in 10 CFR 20.1201(a)(1)(i) and 10 CFR 20.1301(a)) are based on the TEDE.

In 10 CFR Part 20, the NRC defines the EDE as the sum of the products of the dose equivalent to each organ or tissue ( $H_T$ ) and the weighting factors ( $W_T$ ) applicable to each of the body organs or tissues that are irradiated ( $EDE = \sum W_T H_T$ ). Each organ or tissue weighting factor is the proportion of the risk of stochastic effects resulting from the dose to that organ or tissue to the total risk of stochastic effects when the whole body is irradiated uniformly. This formula is applicable whether the dose results from radiation sources internal or external to the body.

In most relatively uniform exposure situations, a single dosimeter calibrated to measure the DDE and worn on the body provides a reasonable measurement of the EDEX. If the body is not irradiated uniformly, a single-dose measurement cannot determine the dose to the various organs and tissues for an accurate determination of the EDEX. To ensure a conservative TEDE determination, 10 CFR 20.1201(c) requires that when an external monitoring device is used to measure external exposure, the DDE, measured for the part of the body receiving the highest exposure, must be used in place of the EDEX unless the EDEX is determined by an NRC approved dosimetry method.

Using the DDE measured at the highest exposed part of the whole body as the EDEX can be overly conservative in extremely non-uniform irradiations (e.g., when only a small portion of the whole body is irradiated). Therefore, several methods acceptable to the NRC staff have been developed to determine the EDEX from dose measurements on the surface of the whole body. Each of these methods generally involves the measurement of the DDE at one or more locations on the whole body. The EDEX is then determined by

### Standardized RP Junior Task Qualifications Study Guide Lesson RP01.01 Revision 2

applying a weighting factor to each dosimeter result. An algorithm that combines multiple measurements may be applied to provide a less conservative determination of the EDEX than that provided by the single dosimeter. Each of these methods has its own advantages and limitations. Care must be exercised to ensure that each method is used within the limitations noted below.

The use of the methods discussed in regulatory guide 8.4 for determining the EDEX component of the TEDE may not eliminate the need to determine the dose at the highest exposed part of the whole body. The regulations at 10 CFR 20.1201(a) and 10 CFR 20.1201(c) require doses to be measured at specific body locations for demonstrating compliance with the non-TEDE dose limits (i.e., dose to the lens of the eye, dose to the skin of the whole body and extremities, or the total organ dose). Licensees will most likely need to provide additional dosimeters if 10 CFR 20.1502, “Conditions Requiring Individual Monitoring of External and Internal Occupational Dose,” requires monitoring to demonstrate compliance with any of these non-TEDE dose limits. Regulatory Guide 8.34, “Monitoring Criteria and Methods to Calculate Occupational Radiation Doses,” issued July 1992 (Ref. 2), provides guidance on meeting the monitoring requirements of 10 CFR 20.1502. Therefore, using the methods described below will not, in most cases, lead to any reduction in monitoring requirements. Instead, they may help provide a more accurate determination of the EDEX than may be possible using a single dosimeter when the radiation fields to which the monitored person is exposed are very non-uniform and particularly when significant parts of the body, especially the torso, are shielded.

**Standardized RP Junior Task Qualifications Study Guide  
Lesson RP01.01 Revision 2**

Using Multiple Dosimetry with Compartment Factors

Section 3.0 of American National Standards Institute (ANSI)/Health Physics Society (HPS) N13.41-1997, "Criteria for Performing Multiple Dosimetry," issued December 1996 (Ref. 3), provides a method for estimating the EDEX from several dosimeter results. This method divides the whole body into seven separate compartments. Each compartment is monitored separately. The measured DDE for each compartment ( $DDE_c$ ) is then weighted with the associated "compartment factor" ( $W_c$ ) as listed in Table 1. The resulting weighted doses are then summed to determine the EDEX for the whole body as follows:

$$EDEX = \sum W_c DDE_c$$

<b>Table 1. Compartment Factors</b>	
<b>AREA OF THE BODY/COMPARTMENT</b>	<b>COMPARTMENT FACTOR (<math>W_c</math>)</b>
Head and neck	0.10
Thorax, above the diaphragm	0.38
Abdomen, including the pelvis	0.50
Upper right arm	0.005
Upper left arm	0.005
Right thigh	0.005
Left thigh	0.005

Standardized RP Junior Task Qualifications Study Guide  
Lesson RP01.01 Revision 2

EO: 1.39 Explain actions to take in the event of abnormal situations, such as lost, damaged, alarming and off-scale high dosimetry, exposure in excess of plant administrative limits or nuclear regulatory limits, and significant differences among multiple dosimeter readings

A. Determine the cause of the alarm.

- When the SRD alarmed, where were you and what activities were you involved in?
- What were the expected dose rates in the area?
- Were you leaning against anything at the time of the alarm? • What activities were going on around you when your SRD alarmed (for example, equipment moving, systems being opened, type of work, high noise area, hearing protection worn)?
- What kinds of equipment were you using or were nearby (for example, welding, special test equipment, large industrial magnets, etc.)?
- Did you drop your dosimeter?
- Were there any co-workers with you in the work area?
- Did you compress your SRD against a hard surface (for example, leaning against a pipe to reach into your work area)?

B. Determine if the alarm was due to a radiation or non-radiation event.

1. For radiologically induced alarms consider:

- a. Changes in plant configuration
- b. Unknown radiological conditions
- c. Working in wrong location
- d. Body position

Standardized RP Junior Task Qualifications Study Guide  
Lesson RP01.01 Revision 2

e. Wrong RWP / Task

2. Obtain dose rate survey
3. CR required for SRD dose or dose rate alarms
4. Estimate worker's exposure
5. Restrict RCA access

C. Lost, Damaged, Suspect Dosimetry

1. If the individual's DLR(s) is lost, damaged, or requires processing, restrict the workers RCA access.
2. Obtain the SRD histogram
3. Initiate a CR
4. Estimate worker's exposure
5. Restrict RCA access

D. Dosimetry analysis

1. If required, the worker's DLR will be processed.

E. Anticipated SRD Dose Rate Alarms

1. If an anticipated SRD Dose Alarm is authorized by an RP Leader:
  - Perform a Pre-Job briefing and Two Minute Drill to discuss expected alarms.
  - Ensure the worker has available dose.
  - Provide continuous or remote surveillance
  - RP Log entries required

## RP Fundamentals for Junior Task Qualifications

### Standardized RP Junior Task Qualifications Study Guide Lesson RP01.01 Revision 2

**Personnel Exposure incidents that require notification to the NRC.**

These fall into three time-reporting categories that have caused or threaten to cause an individual to receive:

Immediate Notification Reports	Twenty-Four Hour Notification Reports	Thirty Day Notification Reports
Total Effective Dose Equivalent (TEDE) $\geq$ 25 rem	Total Effective Dose Equivalent (TEDE) $>$ 5 rem	Doses in excess of the occupational dose limits for adults in 10CFR20.1201.
Eye Dose Equivalent (LDE) $\geq$ 75 Rem	Eye Dose Equivalent (LDE) $>$ 15 Rem	Doses in excess of any of the occupational dose limits for a minor in 10CFR20.1207.
Shallow Dose Equivalent (SDE) To The Skin Or Extremities $\geq$ 250 Rad	Shallow Dose Equivalent (SDE) To The Skin or Extremities $>$ 50 Rem.	Doses in excess of any of the limits for an embryo/fetus of a declared pregnant woman in 10CFR20.1208.
		Doses in excess of any of the limits for an individual member of the public in 10CFR20.1301.
		Doses in excess of any applicable limit in the license.

Standardized RP Junior Task Qualifications Study Guide  
 Lesson RP01.01 Revision 2

EO: 1.40 Define annual limit on intake, derived air concentration, weighting factors, and solubility class

The annual limit on intake is defined in Federal Regulations [10CFR20, Standards for Protection Against Radiation] as follows.

**Annual limit on intake (ALI)** means the derived limit for the amount of radioactive material taken into the body of an adult worker by inhalation or ingestion in a year. ALI is the smaller value of intake of a given radionuclide in a year by the reference man that would result in a committed effective dose equivalent of 5 rems (0.05 Sv) or a committed dose equivalent of 50 rems (0.5 Sv) to any individual organ or tissue. (ALI values for intake by ingestion and by inhalation of selected radionuclides are given in Table 1, Columns 1 and 2, of appendix B to §§ 20.1001-20.2401).

Note that the ALI is defined for each radionuclide, and the ALI value varies based on the radiation hazard (“radiotoxicity”) from each nuclide when ingested or inhaled. The values provided in the regulation in Appendix B of 10CFR20, as described in the definition are the values that would yield a dose at the annual limit to an exposed individual of either 5 rem whole body as represented by the CEDE value or 50 rem to any single organ (CDE). While the ALI is related to the DOSE (for example an intake of 0.2 times an ALI would equate to 1 rem CEDE, or 10 rem CDE, if the individual organ ALI is the lower value), it is helpful to also derive a measurement that equates to the DOSE RATE from airborne activity. This is determined through measurements of airborne concentrations of radionuclides, and gives rise to the concept of the Derived Airborne Concentration (DAC).

Federal regulations (10CFR20), define the DAC as follows;

**Derived air concentration (DAC)** means the concentration of a given radionuclide in air which, if breathed by the reference man for a working year of 2,000 hours under conditions of light work (inhalation rate 1.2 cubic meters of air per hour), results in an intake of one ALI. DAC values are given in Table 1, Column 3, of appendix B to §§ 20.1001-20.2401.

To relate DAC to an effective internal dose rate, consider that from the definition, 2000 hours breathing air with an airborne concentration of one DAC yields a dose of one ALI (5 rem, CEDE for this example) then the dose rate equivalent of one DAC is;

$$1 \text{ DAC} \times 2000 \text{ hrs} = 1 \text{ ALI} = 5 \text{ rem}$$

Then

$$2000 \text{ DAC-hrs} = 5 \text{ rem} \quad \text{or} \quad 1 \text{ DAC-hr} = 5 \text{ rem} / 2000 = 2.5$$

mrem or

$1 \text{ DAC} = 2.5 \text{ rem/hr}$
--------------------------------------

**Standardized RP Junior Task Qualifications Study Guide**  
**Lesson RP01.01 Revision 2**

Note, also from the definition of an ALI, that in some cases an ALI results in a 5 rem CEDE dose, which equals the whole-body annual dose limit, while in other cases an intake of an ALI yields a CDE of 50 rem, the annual dose limit for any single organ. The example of regulatory limits (shown below) for Iodine-131 demonstrates a case where the dose to the target organ because of an intake will exceed the annual limit to the whole-body equivalent. This is evident by the ingestion and inhalation ALI values listed for the target organ (thyroid) being lower than the whole-body equivalent ALI values shown in parentheses in Columns 1 and 2 of Table 1.

## Iodine-131

Atomic No.	Radionuclide	Class	Table 1 Occupational Values			Table 2 Effluent Concentrations		Table 3 Releases to Sewers
			Col. 1	Col. 2	Col. 3	Col. 1	Col. 2	Monthly Average Concentration (µCi/ml)
			Oral Ingestion ALI (µCi)	Inhalation		Air (µCi/ml)	Water (µCi/ml)	
				ALI (µCi)	DAC (µCi/ml)			
53	Iodine-131	D, all compounds	3E+1 Thyroid	5E+1 Thyroid	2E-8	-	-	-
			(9E+1)	(2E+2)	-	2E-10	1E-6	1E-5

**Standardized RP Junior Task Qualifications Study Guide  
Lesson RP01.01 Revision 2**

The target organs are not all equal in their impact to the whole-body dose. As this table shows, the radiosensitivity depends on the nature of the radionuclide’s behavior in the body. The relationship between the dose to a target organ, the CDE, and the effective whole-body dose (CEDE) for comparison of internal and external dose on a common risk basis, is

$CEDE = CDE * W_t$ , where  $W_t$  is the sensitivity of the organ compared to the whole body.

This weighting factor is defined in 10CFR20 as follows.

Weighting factor  $W_T$ , for an organ or tissue (T) is the proportion of the risk of stochastic effects resulting from irradiation of that organ or tissue to the total risk of stochastic effects when the whole body is irradiated uniformly. For calculating the effective dose equivalent, the values of  $W_T$  are:

Organ or Tissue	$W_T$
Gonads	0.25
Breast	0.15
Red bone marrow	0.12
Lung	0.12
Thyroid	0.03
Bone surfaces	0.03
Remainder	<sup>1</sup> 0.30
Whole Body	<sup>2</sup> 1.00

<sup>1</sup> 0.30 results from 0.06 for each of 5 "remainder" organs (excluding the skin and the lens of the eye) that receive the highest doses.

<sup>2</sup> For the purpose of weighting the external whole body dose (for adding it to the internal dose), a single weighting factor,  $w_T=1.0$ , has been specified. The use of other weighting factors for external exposure will be approved on a case-by-case basis until such time as specific guidance is issued.

Note from the table extracted from 10CFR20, that not all organs are assigned the same radiosensitivity and whole-body dose equivalency. For example, the thyroid (an iodine concentrator in the body), has a lower  $W_T$  than the lungs. A human can live without a thyroid, for example, while lungs are a more vital organ. Therefore, as will be presented in a later objective, the limiting ALI for radioactive iodine is related to the CDE (50 rem thyroid dose) rather than the 5 rem CEDE limit because the weighting factor for the target organ is so low.

**Solubility Class**

Because the removal rate of radionuclides ingested or inhaled into the body can change based on chemical composition, the dose to the worker can change accordingly. Therefore, in determining the actual dose from an intake, this chemical characteristic may also be considered. Federal regulations reflect this phenomenon in Table 1 of Appendix B of 10CFR20, where differing values of an ALI are provided for a given radionuclide. For example, the below table taken from 10CFR20 shows differing limits on intake depending

Standardized RP Junior Task Qualifications Study Guide  
Lesson RP01.01 Revision 2

on the chemical nature of the material, as shown by rates of removal from the body in days (D), weeks (W), and years (Y).

## Cobalt-60

Atomic No.	Radionuclide	Class	Table 1 Occupational Values			Table 2 Effluent Concentrations		Table 3 Releases to Sewers
			Col. 1	Col. 2	Col. 3	Col. 1	Col. 2	Monthly Average Concentration (μCi/ml)
			Oral Ingestion ALI (μCi)	Inhalation		Air (μCi/ml)	Water (μCi/ml)	
ALI (μCi)	DAC (μCi/ml)							
27	Cobalt-60	W, see <sup>55</sup> Co	5E+2	2E+2	7E-8	2E-10	3E-6	3E-5
		Y, see <sup>55</sup> Co	2E+2	3E+1	1E-8	5E-11	-	-

EO: 1.41 Explain how annual limit on intake, committed dose equivalent, committed effective dose equivalent, and the target organ relate to the appropriate derived air concentration

As described in the ALI definition, the resultant dose from an intake of 1 ALI for a given radionuclide could result in one of two outcomes which reaches an annual exposure limit.

1. If the limiting dose is to a specific target organ (for example, Strontium 90, shown below) the ALI value provided in regulations will cite the target organ (e.g., bone surface). Thus, an intake of 20 microcuries, would result in a CDE dose of 50 rem to the bone surface.
2. If the limiting dose is to the whole body, the resulting dose would be 5 rem, CEDE.

When the ALI is based on the CEDE, only one value is provided for each nuclide, as in the table shown below for Cesium-137. Note that in this case, an inhalation of 1 ALI (20 microcuries) would result in a dose of 5 rem CEDE.

# Cesium-137

Atomic No.	Radionuclide	Class	Table 1 Occupational Values			Table 2 Effluent Concentrations		Table 3 Releases to Sewers
			Col. 1	Col. 2	Col. 3	Col. 1	Col. 2	Monthly Average Concentration (μCi/ml)
			Oral Ingestion ALI (μCi)	Inhalation		Air (μCi/ml)	Water (μCi/ml)	
	ALI (μCi)	DAC (μCi/ml)						
55	Cesium-137	D, all compounds	1E+2	2E+2	6E-8	2E-10	1E-6	1E-5

# Strontium-90

Atomic No.	Radionuclide	Class	Table 1 Occupational Values			Table 2 Effluent Concentrations		Table 3 Releases to Sewers
			Col. 1	Col. 2	Col. 3	Col. 1	Col. 2	Monthly Average Concentration (μCi/ml)
			Oral Ingestion ALI (μCi)	Inhalation		Air (μCi/ml)	Water (μCi/ml)	
	ALI (μCi)	DAC (μCi/ml)						
38	Strontium-90	D, see <sup>80</sup> Sr	3E+1 Bone Surf	2E+1 Bone Surf	8E-9	-	-	-
			(4E+1)	(2E+1)	-	3E-11	5E-7	5E-6
		Y, see <sup>80</sup> Sr	-	4E+0	2E-9	6E-12	-	-

Standardized RP Junior Task Qualifications Study Guide  
Lesson RP01.01 Revision 2

EO: 1.42 Given 10CFR20 Appendix B, locate derived air concentration values and calculate derived air concentration hours for practical situations involving exposure of individuals to airborne radioactivity

**Derived Air Concentration (DAC):** For the radionuclides listed in Appendix B of 10 CFR 20, the airborne concentration that equals the ALI divided by the volume of air breathed by an average worker for a working year of 2000 hours (assuming a breathing volume of 2400m<sup>3</sup>). For radionuclides listed in Appendix C of 10 CFR 835, the air immersion DACs were calculated for a continuous, non-shielded exposure via immersion in a semi-infinite atmospheric cloud. The values are based upon the derived airborne concentration found in Table 1 of the U. S. Environmental Protection Agency's Federal Guidance Report No. 11, *Limiting Values of Radionuclide Intake and Air Concentration and Dose Conversion Factors for Inhalation, Submersion, and Ingestion*, published September 1988

Explanation of DAC - Excerpt from 10CFR20 Appendix B Table 1 "Occupational Values":

"The derived air concentration (DAC) values are derived limits intended to control chronic occupational exposures. The relationship between the DAC and the ALI is given by:  $DAC = ALI \text{ (in } \mu\text{Ci)} / (2000 \text{ hours per working year} \times 60 \text{ minutes/hour} \times 2 \times 10^4 \text{ ml per minute}) = [ALI / 2.4 \times 10^9] \mu\text{Ci/ml}$ , where  $2 \times 10^4 \text{ ml}$  is the volume of air breathed per minute at work by "Reference Man" under working conditions of "light work."

The DAC values relate to one of two modes of exposure: either external submersion or the internal committed dose equivalents [CDE] resulting from inhalation of radioactive materials. Derived air concentrations based upon submersion are for immersion in a semi-infinite cloud of uniform concentration and apply to each radionuclide separately.

The ALI and DAC values relate to exposure to the single radionuclide named, but also include contributions from the in-growth of any daughter radionuclide produced in the body by the decay of the parent. However, intakes that include both the parent and daughter radionuclides should be treated by the general method appropriate for mixtures.

The value of ALI and DAC do not apply directly when the individual both ingests and inhales a radionuclide, when the individual is exposed to a mixture of radionuclides by either inhalation or ingestion or both, or when the individual is exposed to both internal and external radiation (see § 20.1202). When an individual is exposed to radioactive materials which fall under several of the translocation classifications (i.e., Class D, Class W, or Class Y) of the same radionuclide, the exposure may be evaluated as if it were a mixture of different radionuclides.

**Standardized RP Junior Task Qualifications Study Guide**  
**Lesson RP01.01 Revision 2**

It should be noted that the classification of a compound as Class D, W, or Y is based on the chemical form of the compound and does not consider the radiological half-life of different radioisotopes. For this reason, values are given for Class D, W, and Y compounds, even for very short-lived radionuclides.”

**1.42.1 Locate DAC values in 10CFR20 Appendix B.**

10CFR20 Appendix B can be located on the Nuclear Regulatory Commission (NRC) website at <https://www.nrc.gov/reading-rm/doc-collections/cfr/part020/appb/>.

**1.42.2 Calculate DAC hours for practical situations involving exposure of individuals to airborne radioactivity.**

**Explanation of “Determination of internal exposure.” 10CFR20 § 20.1204**

- (a) For purposes of assessing dose used to determine compliance with occupational dose equivalent limits, the licensee shall, when required under § 20.1502, take suitable and timely measurements of--
- (1) Concentrations of radioactive materials in air in work areas; or
  - (2) Quantities of radionuclides in the body; or
  - (3) Quantities of radionuclides excreted from the body; or
  - (4) Combinations of these measurements.
- (b) Unless respiratory protective equipment is used, as provided in § 20.1703, or the assessment of intake is based on bioassays, the licensee shall assume that an individual inhales radioactive material at the airborne concentration in which the individual is present.
- (c) When specific information on the physical and biochemical properties of the radionuclides taken into the body or the behavior or the material in an individual is known, the licensee may--
- (1) Use that information to calculate the committed effective dose equivalent [CEDE], and, if used, the licensee shall document that information in the individual's record; and
  - (2) Upon prior approval of the Commission, adjust the DAC or ALI values to reflect the actual physical and chemical characteristics of airborne radioactive material (e.g., aerosol size distribution or density); and
  - (3) Separately assess the contribution of fractional intakes of Class D, W, or Y compounds of a given radionuclide (see appendix B to part 20) to the committed effective dose equivalent.

Standardized RP Junior Task Qualifications Study Guide  
Lesson RP01.01 Revision 2

(d) If the licensee chooses to assess intakes of Class Y material using the measurements given in § 20.1204(a)(2) or (3), the licensee may delay the recording and reporting of the assessments for periods up to 7 months, unless otherwise required by §§ 20.2202 or 20.2203, in order to permit the licensee to make additional measurements basic to the assessments.

(e) If the identity and concentration of each radionuclide in a mixture are known, the fraction of the

DAC applicable to the mixture for use in calculating DAC-hours must be either--

(1) The sum of the ratios of the concentration to the appropriate DAC value (e.g., D, W, Y) from appendix B to part 20 for each radionuclide in the mixture; or

(2) The ratio of the total concentration for all radionuclides in the mixture to the most restrictive DAC value for any radionuclide in the mixture.

(f) If the identity of each radionuclide in a mixture is known, but the concentration of one or more of the radionuclides in the mixture is not known, the DAC for the mixture must be the most restrictive DAC of any radionuclide in the mixture.

(g) When a mixture of radionuclides in air exists, licensees may disregard certain radionuclides in the mixture if--

(1) The licensee uses the total activity of the mixture in demonstrating compliance with the dose limits in § 20.1201 and in complying with the monitoring requirements in § 20.1502(b), and

(2) The concentration of any radionuclide disregarded is less than 10 percent of its DAC, and

(3) The sum of these percentages for all of the radionuclides disregarded in the mixture does not exceed 30 percent.

(h)(1) In order to calculate the committed effective dose equivalent, the licensee may assume that the inhalation of one ALI, or an exposure of 2,000 DAC-hours, results in a committed effective dose equivalent of 5 rems (0.05 Sv) for radionuclides that have their ALIs or DACs based on the committed effective dose equivalent.

(2) When the ALI (and the associated DAC) is determined by the non-stochastic organ dose limit of 50 rems (0.5 Sv), the intake of radionuclides that would result in a committed effective dose equivalent of 5 rems (0.05 Sv) (the stochastic ALI) is listed in parentheses in table 1 of appendix B to part 20. In this case, the licensee may, as a simplifying assumption, use the stochastic ALIs to determine committed effective dose equivalent. However, if the licensee uses the stochastic ALIs, the licensee must also demonstrate that the limit in § 20.1201(a)(1)(ii) is met.

Standardized RP Junior Task Qualifications Study Guide  
 Lesson RP01.01 Revision 2

How to calculate DAC hours

For example, locate Cobalt-60 in Appendix B Table 1 at <https://www.nrc.gov/reading-rm/docollections/cfr/part020/appb/>.

# Cobalt-60

Atomic No.	Radionuclide	Class	Table 1 Occupational Values			Table 2 Effluent Concentrations		Table 3 Releases to Sewers
			Col. 1	Col. 2	Col. 3	Col. 1	Col. 2	Monthly Average Concentration (μCi/ml)
			Oral Ingestion ALI (μCi)	Inhalation		Air (μCi/ml)	Water (μCi/ml)	
				ALI (μCi)	DAC (μCi/ml)			
27	Cobalt-60	W, see <sup>55</sup> Co	5E+2	2E+2	7E-8	2E-10	3E-6	3E-5
		Y, see <sup>55</sup> Co	2E+2	3E+1	1E-8	5E-11	-	-

**Activity: Calculate DAC hours for practical situations involving exposure of individuals to airborne radioactivity.**

Using Table 1, Col. 3, value above for Inhalation DAC value for Cobalt-60, calculate DAC hours involving exposure of individuals to airborne radioactivity.

Sample calculation: A worker performed maintenance on a highly contaminated pump for 1.5 hours. Air sample activity is 4.5E-9 microcuries/cc. How much exposure in millirem did the worker receive from the airborne radioactivity due to inhalation?

Answer:  $4.5E-9 \text{ microcuries/cc} / 1 E-8 \text{ microcuries/cc} = 0.45 \text{ fDAC}$

Formula:  $\text{DAC-hr} = \text{fDAC} \times \text{exposure time in hours}$

$\text{DAC-hr} = 0.45 \text{ fDAC} \times 1.5 \text{ hours} = 0.675 \text{ DAC-hrs}$

1 DAC-hr = 2.5 mrem

Therefore,  $0.675 \text{ DAC-hrs} \times 2.5 \text{ mrem} = 1.69 \text{ mrem}$  exposure from inhaling Cobalt-60.

**Standardized RP Junior Task Qualifications Study Guide**  
**Lesson RP01.01 Revision 2**

DAC-hr = The product of the concentration of radioactive material in air times the exposure time, or, 2,000 DAC-hrs can be taken as one ALI, equivalent to a committed effective dose equivalent of 5 rems.

**Compliance Formulas**

ALIs and DACs

Stochastic:

1ALI = 5 rem/year (CEDE) = 2,000 DAC-hrs

1DAC-hr = 2.5 mrem

Non-Stochastic:

1ALI = 50 rem/year (CDE) = 2,000 DAC-hrs

1DAC-hr = 25 mrem

EO: 1.43 Define biological half-life and effective half-life

Half-life (radiological) - The time required for half the atoms of a particular radioisotope to decay into another isotope. A specific half-life is a characteristic property of each radioisotope. Measured half-lives range from millionths of a second to billions of years, depending on the stability of the nucleus. Radiological half-life is related to, but different from, the biological half-life and the effective half-life.

Radioactive half-life ( $T_R$ ) - the time it takes for one half of the radioactive material to decay.

Biological half-life ( $T_B$ ) - The time it takes for one half of the originally deposited radionuclide to be eliminated from the body due to the natural biological process.

Effective half-life ( $T_E$ ) - The time it takes for the activity of a radionuclide in the body to be one half of its original value as a result of the radioactive decay and the biological elimination.

**Effective half-life formula:  $T_E = T_R \times T_B / T_R + T_B$**

NOTE: Uncertainties come from the complexities of human metabolic rates and the statistical anomalies.

Standardized RP Junior Task Qualifications Study Guide  
Lesson RP01.01 Revision 2

EO: 1.44 Describe requirements for monitoring and reporting internal exposure

**10CFR20 § 20.1502 Conditions requiring individual monitoring of...internal occupational dose.**

Each licensee shall monitor exposures to radiation and radioactive material at levels sufficient to demonstrate compliance with the occupational dose limits of this part. As a minimum—

(b) Each licensee shall monitor (see § 20.1204) the occupational intake of radioactive material by and assess the committed effective dose equivalent to—

- (1) Adults likely to receive, in 1 year, an intake in excess of 10 percent of the applicable ALI(s) in table 1, Columns 1 and 2, of appendix B to §§ 20.1001-20.2402;
- (2) Minors likely to receive, in 1 year, a committed effective dose equivalent in excess of 0.1 rem (1 mSv); and
- (3) Declared pregnant women likely to receive, during the entire pregnancy, a committed effective dose equivalent in excess of 0.1 rem (1 mSv)<sup>2</sup>.

[56 FR 23398, May 21, 1991, as amended at 60 FR 20185, Apr. 25, 1995; 63 FR 39482, July 23, 1998]

<sup>2</sup>All of the occupational doses in § 20.1201 continue to be applicable to the declared pregnant worker as long as the embryo/fetus dose limit is not exceeded.

**§ 20.2206 Reports of individual monitoring.**

(a) This section applies to each person licensed by the Commission to--

- (1) Operate a nuclear reactor designed to produce electrical or heat energy pursuant to § 50.21(b) or § 50.22 of this chapter or a testing facility as defined in § 50.2 of this chapter; or
- (2) Possess or use byproduct material for purposes of radiography pursuant to Parts 30 and 34 of this chapter; or
- (3) Possess or use at any one time, for purposes of fuel processing, fabricating, or reprocessing, special nuclear material in a quantity exceeding 5,000 grams of contained uranium-235, uranium-233, or plutonium, or any combination thereof pursuant to part 70 of this chapter: or
- (4) Possess high-level radioactive waste at a geologic repository operations area pursuant to part 60 or 63 of this chapter; or

**Standardized RP Junior Task Qualifications Study Guide**

**Lesson RP01.01 Revision 2**

- (5) Possess spent fuel in an independent spent fuel storage installation (ISFSI) pursuant to part 72 of this chapter; or
- (6) Receive radioactive waste from other persons for disposal under part 61 of this chapter; or
- (7) Possess or use at any time, for processing or manufacturing for distribution pursuant to parts 30, 32, 33 or 35 of this chapter, byproduct material in quantities exceeding any one of the following quantities:

<b>Radionuclide</b>	<b>Quantity of radionuclide<sup>1</sup> in curies</b>
Cesium-137	1
Cobalt-60	1
Gold-198	100
Iodine-131	1
Iridium-192	10
Krypton-85	1,000
Promethium-147	10
Technetium-99m	1,000

<sup>1</sup>The Commission may require as a license condition, or by rule, regulation, or order pursuant to § 20.2302, reports from licensees who are licensed to use radionuclides not on this list, in quantities sufficient to cause comparable radiation levels.

(b) Each licensee in a category listed in paragraph (a) of this section shall submit an annual report of the results of individual monitoring carried out by the licensee for each individual for whom monitoring was required by § 20.1502 during that year. The licensee may include additional data for individuals for whom monitoring was provided but not required. The licensee shall use Form NRC 5 or electronic media containing all the information required by Form NRC 5.

(c) The licensee shall file the report required by § 20.2206(b), covering the preceding year, on or before April 30 of each year. The licensee shall submit the report to the REIRS Project Manager by an appropriate method listed in § 20.1007 or via the REIRS Web site at <http://www.reirs.com>.



EO: 1.45 State the purpose of having plant administrative limits for radiation exposure

Title 10, Part 20, of the *Code of Federal Regulations*, 10CFR20, "Standards for Protection Against Radiation," establishes the dose limits for radiation workers.

The dose limits established by 10CFR20 are the federal legal limits for exposure that a licensee can permit a worker to be exposed to. If federal limits are not maintained, serious violations can occur, resulting in several possible consequences, e.g., increased risk of adverse health effects, NRC fines of the plant, disciplinary actions for willful violations and increased regulatory oversight by the NRC.

Administrative limits for exposure to ionizing radiation are set by licensees to minimize the risk of challenging the legal dose limits set in 10CFR20 and as a method to limit exposures to workers at licensee facilities. All workers, supervisors and managers working in commercial nuclear power must work to reduce and control radiation exposure. Administrative limits are a tool that facilitate exposure controls.

EO: 1.46 Explain the differences between general area dose rate and contact dose rate and how each is used in controlling exposures

A major task for RP technicians is to perform surveys so that an area's radiological conditions are understood and comprehensively represented to brief workers (*extracted from INPO 05-008, Rev 03*). During the performance of surveys, dose rates in general areas and on contact with components and surfaces in the area documented.

General area dose rates are established by conducting a 'General Area Survey', which is defined as a dose rate survey performed in the general area at least 30 cm from the radiation source or from any surface that radiation penetrates (*extracted from NISP-RP-013, rev 00*). General area dose rates are important for establishing stay times for personnel entering the area and for deriving estimates of whole-body exposures that will aid job planning and establishment of exposure controls.

Contact dose rates are dose rate measurements taken by placing the radiation detector housing on the surface being measured (*extracted from NISP-RP-013, rev 00*). These are important for establishing expected rates of exposure to the extremities when specific work requires having extremities in contact with components which have a measurable dose rate. The determination to use extremity dosimetry and to require component decontamination are the result of documenting contact dose rates.

Standardized RP Junior Task Qualifications Study Guide  
Lesson RP01.01 Revision 2

EO: 1.47 Describe dose reduction techniques that can be used by technicians to reduce workers' radiation exposures.

“Dose reduction techniques such as effective engineering controls, including shielding, robots, long-handled tools and remote monitoring, and other techniques, are used to limit worker dose” (*extracted from INPO 05-008, Rev 03*).

Temporary Shielding is radiation-attenuating materials (usually vinyl-encased lead or tungsten) that is temporarily installed for a specific duration to reduce work area or general area dose rates in support of plant work activities and is removed at the completion of the work activity. Sometimes temporary shielding is installed in contact with and physically supported by the component being shielded, if load capacities are formally considered and calculations are completed to ensure equipment is not overloaded. (*Extracted from Exelon RPTI 8.18*).

Long-handled tools can include simple hand tools, such as pliers, which keep a worker's hands away from a component, but are generally purpose-built devices that allow a worker to handle components or complete a task from a distance.

Robotics can be used to obtain photos, dose rates, smears, samples, and to perform some work group tasks in areas of high dose rates. Using a robot to transit areas of higher dose rates or a drone to fly into expansive areas allow some functions to be performed without a worker being required to enter. Considerations must be made for a backup plan in case of robotics failures, but typically, when robotics can be used worker exposure is reduced.

Remote monitoring systems use cameras, telemetry, and radio or wired communications to allow RP Technicians to give detailed directions to workers, allowing them to re-position themselves to reduce their exposure. When this option is available, a technician watching the job on camera and monitoring each worker's accumulated dose, can give specific instructions to each worker to reduce their exposure while the job is in progress.

Other dose reduction techniques include remove the source material; moving the work to a lower dose area; flushing of piping / components; decontamination to remove source term; use of HEPA ventilation to remove/control airborne radioactivity; use of low dose areas; and transit planning to avoid areas of elevated dose rates.

Standardized RP Junior Task Qualifications Study Guide  
Lesson RP01.01 Revision 2

EO: 1.48 Describe the effects from stellite being present in reactor coolant.

Stellite is the trademarked name for various alloys of chromium and cobalt that are formulated to be wear-resistant. Stellite is used in applications where a tough surface is required for components subject to movement with metal-to-metal contact. Stellite alloys are corrosion-resistant, nonmagnetic, and may be formulated to resist hardening, or annealing or to have extreme wear resistance. Some metallic parts subject to repetitive metal to metal contact are lined or coated with Stellite.

In the nuclear power industry, Stellite was originally used for valve seats, pump seals, roller bearings on control rods, and the leading edges of turbine blades, among other applications. While providing good wear-resistance, the Cobalt-59 in the Stellite alloy became a significant contributor to personnel exposure. When atoms of Cobalt-59 are subjected to a neutron flux in the reactor core, they absorb a neutron, and become activated, yielding Cobalt-60, a long-lived radioactive isotope. At one time in Boiling Water Reactors, the roller bearing on control rod, the seats of various primary system valves and the turbine blades were each shedding a small amount of Cobalt-59 from their wear surfaces which was transported through the reactor core and irradiated by the neutron flux, creating Cobalt -60. In Pressurized Water Reactors, the wear products were largely limited to valve seats, resulting in a smaller amount of Cobalt-60.

The effects of having Stellite present in the reactor coolant are increased amounts of Cobalt-60 in the coolant, higher levels of loose contamination associated with the primary system and subsequent increased nuclear worker exposures.

The industry realized this condition was contributing to a significant amount of worker exposure and began the decades-long process of replacing Stellite in systems associated with the reactor and cleaning up the system piping and components to remove existing Cobalt-60.

EO: 1.49 Explain the difference between loose and fixed contamination

Contamination is simply defined as radioactive material in an unwanted location, e.g., personnel work areas, etc. Two types are possible:

**Fixed Contamination** - Radioactive surface contamination that is not easily transferred to other personnel or equipment through normal contact.

**Loose Contamination** - Radioactive surface contamination that is easily transferred to other personnel or equipment through normal contact.

Removable contamination is measured by a transfer test using a suitable sampling material. Common materials used for the monitoring are the standard paper disk smear or cloth smear. The standard technique involves wiping approximately 100 cm<sup>2</sup> of the surface of interest using moderate pressure. A common sampling practice used to ensure a 100 cm<sup>2</sup> sample is to wipe a 16 square inch "S" shape on the surface (i.e., four inches by four inches). Qualitative, large area wipe surveys may be taken using other materials, such as Masslin-cloth or Kimwipe, to indicate the presence of removable contamination. These are commonly used when exact levels of contamination are not required.

Fixed contamination is measured by use of a direct survey technique. This technique, commonly referred to as "frisking," indicates the total contamination on a surface apparent to the detector from both fixed and removable. To evaluate the fixed component the removable level must be subtracted from the total when non-removable levels are to be recorded.

EO: 1.50 Discuss the reason for having lower limits for alpha contamination

### **Biological Effect of Internal Alpha Exposure**

The presence of Alpha contamination poses a potential internal exposure hazard to personnel if proper monitoring and controls are not in place. The RBE (Relative Biological Effectiveness) of Alpha radiation is higher than that of Beta or Gamma radiation. The RBE quantifies the ability of radiation to cause biological effects such as cancer or cell-death, for equivalent radiation exposure. The RBE is usually expressed as a ratio of biological effectiveness of one type of ionizing radiation to another, given the same amount of absorbed energy. The higher RBE value for Alpha radiation is due to the High LET (Linear Energy Transfer) of an Alpha Particle interaction with matter. The RBE has been set at a value of 20 for Alpha Radiation. (Neutron is 10 RBE and Beta-Gamma is 1 RBE). Alpha contamination ingestion/inhalation can affect the delicate internal workings of the living cell forming the lining of the lungs or internal organs. This is due to the high specific ionization of the Alpha particles.

Once in body, the Alpha particle is surrounded by living tissue and has only a short range of travel and the high specific ionization which occurs in the localized area near the point of origin of the Alpha particle. Thus, greater damage can be done to small essential organs of the body if Alpha particles are lodged within them. Because all the Alpha particles energy will be absorbed in that organ and not spread out over a larger volume of tissue. It has been determined that the denser the energy deposited along the path of the Alpha particle interaction with the organ tissue; more damage can be found in the organ tissue. Meaning the contacted cells certainly can be changed (mutated) or killed outright by the energetic Alpha particles.

Standardized RP Junior Task Qualifications Study Guide  
Lesson RP01.01 Revision 2

EO: 1.51 Define cross-contamination, and describe how it can result in the uncontrolled spread of contamination

***Cross-Contamination:***

The definition of cross-contamination is the uncontrolled spreading of radioactive contamination on/into people, places or things.

A major hazard associated with contamination is that often, it may be readily spread. As a result, contamination may be found far from the area where it originated. Generally, we speak of contamination as either being fixed or loose (smearable, spreadable, moveable, etc.).

Whether contamination is fixed or loose is dependent on many factors, such as:

- 1) Porosity of contaminated surface
- 2) Physical form of contaminant
- 3) Chemical bonding
- 4) Electrostatic forces
- 5) Ambient air conditions

Fixed Contamination is radioactive material that cannot be removed from a surface or is absorbed into the surface. In addition, consideration must be given to the degree that a contaminant is fixed. Some contaminants may be so strongly bonded to a surface that removal may require abrasion of the surface; other contaminants may be transported by slight air currents. The degree that a contaminant may be fixed will vary between these extremes. In general, if contamination does not come off when the surface is smeared, it is fixed contamination.

Leaching is a phenomenon has been observed where, hours or days after decontamination of an item has been performed, the contamination levels have increased. Radioactive material that has been deposited in the pores of the item physically migrates to the surface and is exhibited as removable (smearable) contamination. Even with seemingly non-porous materials, such as stainless steel, leaching has been observed. Commonly contaminated lead has a history of exhibiting leaching. Other materials suspected of leaching would be those subject to the oxidation process. Leaching becomes a concern when materials have been released from a radiologically controlled area as meeting specific removable contamination guidelines and later are found to be contaminated. Significant consequences may result from such a situation. Therefore, care must be taken to recognize the potential for leaching to prevent such occurrences.

**Standardized RP Junior Task Qualifications Study Guide**  
**Lesson RP01.01 Revision 2**

Loose Surface Contamination is the deposition of radioactive material in any place where it is not desired. Processes such as: grinding, peeling of contaminated painted surfaces, scaling, or drying of contaminated components or open systems can produce loose contamination.

Cross Contamination occurs after the initial contamination event and the contamination may be transported or spread to other areas of the facility. Some of the ways that contamination may be spread are:

Contaminated dust may become airborne and carried to uncontaminated areas by ventilation systems. Improper decontamination techniques or work habits. Transferred to personnel clothing and skin and transport to uncontaminated areas. Releasing of contaminated equipment to uncontaminated areas.

EO: 1.52 Identify potential sources of radioactive contamination, including work operations that can generate contamination

### **Sources of Contamination**

Contamination originates primarily from releases of airborne or liquid radioactivity to the surrounding area from systems or components. Contamination is likely to result from equipment failures, human error and maintenance operations

#### **Equipment Failures:**

Plant systems that contain radioactive liquids, solids, or gases (air) can develop leaks to the surrounding area. These leaks are typically found at pipe flanges, sealing surfaces (such as pump seals, manways, handholes), through valve packing or other piping and equipment failures that can release radioactive materials into the surrounding areas. Sealed sources that are used for equipment calibrations or instrumentation source checks can also developed leaks.

#### **Human Errors:**

Human errors can occur when performing tasks either remotely or hands-on. Operating experience has shown that these errors such as: improper system valve lineup, overfilling of tanks, over pressurization of equipment/systems, improper use of equipment/tools, improper identification of systems/components to be opened (aka breached), and improper handling of radioactive materials.

#### **Maintenance Operations:**

Performance of maintenance operations often produces contamination by opening systems and components containing airborne or liquid radioactivity. Examples of this would be maintenance on system components that require grinding, welding or cutting contaminated components.

EO: 1.53 Explain the characteristic difference between particulate, iodine, tritium, and noble gases and how they affect the method of detecting and controlling airborne radioactivity

Noble Gas samples are collected using a specific volume container, but the others are sampled by capture methods. A known volume of air is directed through filter or capture media to determine a concentration per unit volume.

Noble Gas Sampling – Evacuation of known volume container

Particulates – Known volume of air pulled through filter media

Iodine- Known volume of air pulled through filter media

Tritium – Known volume of air aspirated through demineralized water for collection.

EO: 1.54 Explain the purpose of radiation work permits (RWPs), the typical requirements for their use, the difference between general and job-specific RWPs and when each of them is used

Radiological Work Permit (RWP): Permit that identifies radiological conditions, establishes worker protection and monitoring requirements, and contains specific approvals for radiological work activities. The radiological work permit serves as an administrative process for planning and controlling radiological work and informing the worker of the radiological conditions.

The RWP is an administrative mechanism used to establish radiological controls for intended work activities. The RWP informs workers of area radiological conditions and entry requirements and provides a mechanism to relate worker exposure to specific work activities. Use of Radiological Work Permits

Many facilities find it effective to use two different types of RWPs. General RWPs are used for entry and repetitive work in areas with known and stable low-hazard radiological conditions. Job specific RWPs are used for more complex work and for entry into higher-hazard areas.

1. RWPs should be used to control the following activities:
  - a. Entry into radiological areas
  - b. Handling of materials with removable contamination that exceed the industry limits
  - c. Work in localized benchtop areas, laboratory fume hoods, sample sinks, and containment devices that has the potential to generate contamination in areas that are otherwise free of contamination
  - d. Work that disturbs the soil in soil contamination areas
  - e. Work that involves digging in underground radioactive material areas
2. Radiological surveys should be routinely reviewed to evaluate the adequacy of RWP requirements. RWPs should be updated if radiological conditions change to the extent that protective requirements need modification.
3. RWPs should be posted at the access point to the applicable radiological work area or otherwise made available at the work location.

Standardized RP Junior Task Qualifications Study Guide

Lesson RP01.01 Revision 2

4. Workers should acknowledge by signature, or through electronic means where automated access systems are in place, that they have read, understand, and will comply with the RWP prior to initial entry to the area and after any revisions to the RWP.
5. Worker pocket or electronic dosimeter readings should be recorded in a format that identifies and provides linkage to the applicable RWP.

An alternative formal mechanism, such as written procedures or experiment authorizations, may be used in lieu of an RWP as the administrative control over radiological work activities. If an alternative mechanism is used, it should meet the industry standards established. **Job Specific RWP vs. General RWP**

1. Job-specific RWPs should be used to control non-routine operations or work in areas with changing radiological conditions. The job specific RWP should remain in effect only for the duration of the job.
2. General RWPs may be used to control routine or repetitive activities, such as tours and inspections or minor work activities, in areas with well-characterized and stable radiological conditions. General RWPs should not be approved for periods longer than 1 year.

EO: 1.55 Identify the information that should be included on RWPs.

The RWP should include the following information:

1. Description of work
2. Work area radiological conditions
3. Dosimetry requirements
4. Pre-job briefing requirements, as applicable
5. Training requirements for entry
6. Protective clothing and respiratory protection requirements
7. Radiological Control coverage requirements and stay time controls, as applicable
8. Limiting radiological conditions that may void the RWP
9. Special dose or contamination reduction considerations
10. Special personnel frisking considerations
11. Technical work document number, as applicable
12. Unique identifying number
13. Date of issue and expiration
14. Authorizing signatures.
15. The RWP should be integrated with other work authorizations that address safety and health issues, such as those for industrial safety and hygiene, welding, or confined space entry.

If necessary to ensure appropriate accounting, the RWP number should be used in conjunction with the radiation dose accounting system to relate individual and/or collective dose to specific activities.

EO: 1.56 Explain the purpose of having each worker read and log in on the RWP and the administrative process of logging in on an RWP

The Radiation Work Permit (RWP) is an acknowledgement by the worker that they have read, understand, and will comply with the radiological requirements for the task they are to perform.

The process for signing onto a RWP may be electronic using a computer system or on paper. The worker's signature acknowledges that they understand the radiological conditions and will comply with the limitations set forth by the RWP.

These permits are typically generated by the Radiation Protection department and as such the Radiation Protection Technician will be viewed as the expert and may be asked questions pertaining to a worker's specific job.

Standardized RP Junior Task Qualifications Study Guide  
Lesson RP01.01 Revision 2

EO: 1.57 Describe the purpose and use of single and multiple step-off pads in controlling the spread of contamination

**Step-off Pad Purpose and Use:**

The use of step-off pads (SOP) provides an effective method of contamination control by serving as:

- 1) A boundary of the contaminated area.
- 2) The access point to the contaminated area.
- 3) A double SOP is for Highly Contaminated Areas and Discrete Radioactive Particle Zones/Areas.

Step-off pads are provided at access points to contaminated areas adjacent to the contaminated area boundary. Located in low dose waiting areas. Step-off pads are considered radiologically clean. In the areas of high contamination, an additional step-off pad (double step-off pad) may be used. In that case, one step-off pad marks an area of lower contamination and the other is considered clean.

An example of this is during refueling outages. There is sometimes a step-off pad for individuals leaving the cavity while there is another just outside the upper cavity area, which is the lower contamination area. Step-off pads should not be located in areas where a safety hazard may result, such as in stairwells or elevators.

**SOP Removal Process for using a Single Step-off Pad:**

While in contaminated area: Remove protective clothing except inner booties and cotton glove liners. Discard clothing and trash into appropriate containers.

When stepping onto Step-off Pad:

- 1) With back towards the SOP, remove one bootie and place foot on step-off pad. Repeat for other bootie.
- 2) Discard shoe covers in appropriate container.

While in Clean Area:

- 1) Pick up dosimetry/hard hat and proceed to the nearest frisking station.
- 2) Monitor yourself, cotton liners, and dosimetry for contamination.
- 3) Remove cotton glove liners and place them in the appropriate container.

**Standardized RP Junior Task Qualifications Study Guide  
Lesson RP01.01 Revision 2**

**SOP Removal Process for using a Double Step-off Pad:**

In Highly Contaminated Area: Remove all outer protective clothing except shoe covers. Discard clothing/trash in appropriate receptacle.

Stepping onto first (inner) Step-off Pad: Remove outer shoe cover using same procedure as discussed for stepping onto single Step-off Pad. Discard outer shoe covers in appropriate receptacle.

In lower Contaminated Area: Remove protective clothing except inner shoe covers and inner gloves. Discard clothing/trash in appropriate receptacles.

Stepping onto second (outer) Step-off Pad: See steps outlined for single Step-off Pad

Discrete Radioactive Particle (DRP) Areas: A tacky Step-off Pad should be used at the exit of DRP areas

EO: 1.58 Describe techniques used to prevent the spread of contamination when bringing contaminated materials out of posted areas

**Removing Material from a Contaminated Area:**

Prior to any personnel removing items/equipment from a contaminated area; it is required that the workers first notify RP of their intent to remove the items/equipment. RP then coordinates with the workers to have RP job coverage provided for removal of equipment from a Contaminated Area. One of the following methods are to be used when removing materials from a contaminated area:

- 1) Items may be placed in a bag, container or wrapped as they are removed from the contaminated area and taken directly to a location established for surveying and labeling/tagging the items/equipment.
- 2) Items not contained, but under RP control while in a contaminated area; may be removed from contaminated area as long as it has been decontaminated and proven "Clean" smearable survey has obtained.
- 3) With RP concurrence and maintained in continuous line of sight of an item, which has positive control maintained over it and has not come in contact with any contaminated surfaces, may be released from a contaminated area without bagging or survey.

**Control of Radioactive Material Temporarily Released**

With RP Supervisor approval, items which have been surveyed and found to be radioactive can be temporarily released based on the following criteria:

- 1) Item is labeled as radioactive material in accordance with NISP-RP-04, Radiological Posting and Labeling.
- 2) No loose surface contamination
- 3) No potential for spills or leaks
- 4) Item is being transported to an area that satisfies NISP-RP-04, Radiological Posting and Labeling, and proper radiological controls have been established.
- 5) Individual transporting the material is logged in on the appropriate RWP and understands the requirements of transporting the material directly to the radioactive materials area.
- 6) The dose rate on the item is <2.0 mrem/hr at 30cm.
- 7) Conditionally released items are to be documented on Attachment 2, Radioactive Material Log, or similar document.

Standardized RP Junior Task Qualifications Study Guide  
Lesson RP01.01 Revision 2

EO: 1.59 Identify the isotopes of primary concern for airborne radioactivity at a plant

<https://www.epa.gov/radiation/radionuclide-basics-americium-241> use this link to include information about AM-241 for airborne isotopes of concern section.

<https://www.epa.gov/radiation/radionuclide-basics-iodine> use this link to include information about I-131 for airborne isotopes of concern section.

<https://www.epa.gov/radiation/radionuclides>

Use this link to include some specifics about each isotope of concern for airborne radioactivity at nuclear power plants. That way more questions could be created from this material.

Radon is a naturally occurring radioactive gas resulting from the decay of uranium-238 which concentrates in the closed spaces such as buildings and underground mines particularly in early uranium mines which sometimes became a significant hazard before the problem was understood and controlled by increased ventilation. Radon has decay products that are short lived alpha emitters and deposit on surfaces in the respiratory tract during the passage of breathing air. At high radon levels this can cause an increase in lung cancer particularly for smokers (Smoking itself has very much lot greater lung cancer effect than radon)

People everywhere are typically exposed to around 0.2 millisieverts per year and after an up to three (3) millisieverts per year, due to radon (mainly from the inhalation in their homes) without apparent ill effect. Where deemed necessary radon levels in buildings and mines can be controlled by ventilation and measures can be taken in new construction to prevent radon from entering buildings.

However, radon levels of up to 3700 becquerels per cubic meter in some dwellings at Ramsar in Iran have no evident ill-effect. Here, a study (Mortazavi et al, 2005) showed that the highest lung cancer mortality rate was where radon levels were normal, and the lowest rate was where radon concentrations were the highest. The international council for radiation protection (ICRP) recommends keeping workplace radon below 300 becquerels per cubic meter, equivalent to about 10 millisieverts per year. Above this, workers should be considered as occupationally exposed, and subject to the same monitoring as nuclear industry workers. The normal indoor radon concentration ranges from 10 to 100 becquerels per cubic meter but may naturally reach 10,000 becquerels per cubic meter according to UNEP.

**Standardized RP Junior Task Qualifications Study Guide**  
**Lesson RP01.01 Revision 2**

Origin of Radioactivity in Nuclear Power Plants

Nuclear power reactors are fueled with uranium that is slightly enriched in the isotope uranium 235. This isotope is capable of sustaining a controlled nuclear chain reaction that is necessary for production of electrical energy. This chain reaction results in the production of neutrons that induce radioactivity in the fuel, cooling water, and structure components of the reactor.

Radioactivity is induced primarily through the processes involving the capture of neutrons by uranium atoms in the fuel. Fission occurs when the nucleus of a uranium 235 atom (less common uranium 238) captures a neutron, becomes unstable, and splits into two and three lighter nuclei. These nuclei are referred to as fission products. The most common fission products are strontium 90 and cesium 137. Noble gases, for example krypton 85 and xenon 133 can also be produced from fission products. Halogens, like iodine 131 and tritium (from ternary fission of uranium atoms) can also be created.

Standardized RP Junior Task Qualifications Study Guide  
Lesson RP01.01 Revision 2

EO: 1.60 Relate major isotopes expected to be present in the event of fuel damage and the types of surveys used to assess their radiological hazards.

General Information and Rad issues

- One hour after shutdown, the core inventory is 397.42 million Curies of noble gases.
- In the first two weeks after shutdown, short-lived noble gases inside the spent fuel are the significant nuclides.
- The skin dose from Kr85 is approximately 100 times the whole body.

Readings from sealed GM-tube Area Radiation Monitors (ARMs) will not accurately reflect the skin dose hazard posed by Kr85 released during a fuel-handling incident.

**Two Basic Scenarios for Fuel Handling Incident:**

- One or more bundles drop into the fuel pool or reactor cavity areas and breaks open.
- This releases the gaseous contents within the fuel rods into the refuel water.
- Affected ARMs may or may not alarm because of the high ratio of beta emitters to gamma emitters in the released gasses.
- Personnel may be subsequently exposed to noble gas and iodine vapor activity.

This yields immersion dose from the noble gas and thyroid dose from the iodine

Second Scenarios for Fuel Handling Incident

- A bundle is inadvertently removed from the water or is brought too near the surface of the water.
- In either case ARMs will alarm.
- Personnel may be exposed to very high levels of radiation emitted from the irradiated bundle.

Standardized RP Junior Task Qualifications Study Guide  
 Lesson RP01.01 Revision 2

In each case, the MCR will initiate procedures that will evacuate the affected area and direct initial response

Relate major isotopes expected to be present in the event of fuel damage and types of surveys used to assess their radiological hazards.

Reactor accidents can release a variety of radioisotopes into the environment. Table 1 lists the radioisotopes that were released during the Chernobyl accident.

**Table 1. Estimated Releases of Isotopes during the Chernobyl Accident.\***

Isotope	Half-Life	Type of Radiation	Estimated Release during Accident†
			PBq
Neptunium-239	58 hr	Beta, gamma	95
Molybdenum-99	67 hr	Beta, gamma	>168
Tellurium-132	78 hr	Beta, gamma	1150
Xenon-133	5 days	Beta, gamma	6500
Iodine-131	8 days	Beta, gamma	1760
Barium-140	13 days	Beta, gamma	240
Cerium-141	33 days	Beta, gamma	196
Ruthenium-103	40 days	Beta, gamma	>168
Strontium-89	52 days	Beta	115
Zirconium-95	65 days	Beta, gamma	196
Curium-242	163 days	Alpha	0.9
Cerium-144	285 days	Beta, gamma	116
Ruthenium-106	1 yr	Beta, gamma	>73
Cesium-134	2 yr	Beta	54
Plutonium-241	13 yr	Beta	6
Strontium-90	28 yr	Beta	10
Cesium-137	30 yr	Beta, gamma	85
Plutonium-238	86 yr	Alpha	0.035
Plutonium-240	6,850 yr	Alpha, gamma	0.042
Plutonium-239	24,400 yr	Alpha, gamma	0.030

\* Data are from the Nuclear Energy Agency.<sup>8</sup>

† A petabecquerel (PBq) equals 10<sup>15</sup> becquerels (decays per second).

An irradiated fuel rod that breaks out of the water will show radioactive gases of Kr-85 and Xe-133 along with I-131.

- Spill/Spread of contamination
  - Primary isotope are Co<sup>58</sup>, Co<sup>60</sup>, and Cs<sup>137</sup>
  - Mn<sup>54</sup> and Fe<sup>59</sup> may be present
- Steam leaks

**Standardized RP Junior Task Qualifications Study Guide  
Lesson RP01.01 Revision 2**

- Noble gases (Xenon, Krypton)
- Iodine for internal exposure (predominately I-131)

Standardized RP Junior Task Qualifications Study Guide  
Lesson RP01.01 Revision 2

EO: 1.61 Identify and explain the techniques for reducing the volume of radioactive solid waste generated.

One of the potential consequences of working with radioactive materials is the generation of radioactive waste. This radioactive waste needs to be properly disposed.

Examples of radioactive waste include:

- Paper
- Gloves
- Glassware
- Rags
- Brooms, mops

The ALARA concept also applies to minimizing radioactive waste. This will reduce personnel exposure associated with the handling, packaging, storing, and disposing of radioactive waste. This will also reduce the resultant costs. It is very important for each radiological worker to minimize the amount of radioactive waste generated.

Methods to minimize radioactive waste

The following information identifies methods to minimize radioactive waste.

- 1) Minimize the materials used for radiological work.
  - a) Take only the tools and materials you need for the job into areas controlled for radiological purposes. This is especially important for contamination areas.
  - b) Unpack equipment and tools in a clean area. This will help to avoid bringing unnecessary material to the job site. This material can become radioactive waste if it is contaminated.
  - c) Use tools and equipment that are identified for radiological work when possible, such as a hot tool room.
  - d) Use only the materials required to clean the area. An excessive amount of bags, rags, and solvent adds to radioactive waste.
  - e) Sleeve, or otherwise protect with a covering such as plastic, clean materials brought into contaminated areas.
- 2) Separate radioactive waste from nonradioactive waste.

**Standardized RP Junior Task Qualifications Study Guide**

**Lesson RP01.01 Revision 2**

- a) Place radioactive waste in the containers identified for radioactive waste. Do not place radioactive waste in nonradioactive waste containers.
  - b) Do not throw nonradioactive waste, or radioactive material that may be reused, into radioactive waste containers.
- 3) Separate compactable material from non-compactable material.
- 4) Minimize the amount of mixed waste generated. Mixed waste is waste that contains both radioactive and hazardous materials.
- 5) Use good housekeeping techniques.

EO: 1.62 Describe system components and configurations that can result in the accumulation of radioactivity.

The system components and configurations that will collect radioactivity are filters, strainers, ion exchangers. The accumulation of radioactivity is specific to particulate. The other significant areas where radioactivity will typically collect is in low flow areas, drain valves, isolated systems, and floor drains. There are also examples in the industry of additional places include flow meters and pumps associated with the liquid radwaste system. This can lead to a challenge when hooking hoses to drain valves for draining a system for maintenance.

EO: 1.63 Compare the operating characteristics of centrifugal pumps with those of positive displacement pumps

## Pumps

### Centrifugal pumps

Centrifugal pumps basically consist of a stationary pump casing and an impeller mounted on a rotating shaft. The pump casing provides a pressure boundary for the pump and contains channels to properly direct the suction and discharge flow. The pump casing has suction and discharge penetrations for the main flow path of the pump and normally has small drain and vent fittings to remove gases trapped in the pump casing or to drain the pump casing for maintenance. The Figure below is a simplified diagram of a typical centrifugal pump that shows the relative locations of the pump suction, impeller, volute, and discharge. The pump casing guides the liquid from the suction connection to the center, or eye, of the impeller. The vanes of the rotating *impeller* impart a radial and rotary motion to the liquid, forcing it to the outer periphery of the pump casing where it is collected in the outer part of the pump casing called the volute. The *volute* is a region that expands in cross-sectional area as it wraps around the pump casing. The purpose of the volute is to collect the liquid discharged from the periphery of the impeller at high velocity and gradually cause a reduction in fluid velocity by increasing the flow area. This converts the velocity head to static pressure. The fluid is then discharged from the pump through the discharge connection.

Standardized RP Junior Task Qualifications Study Guide  
 Lesson RP01.01 Revision 2

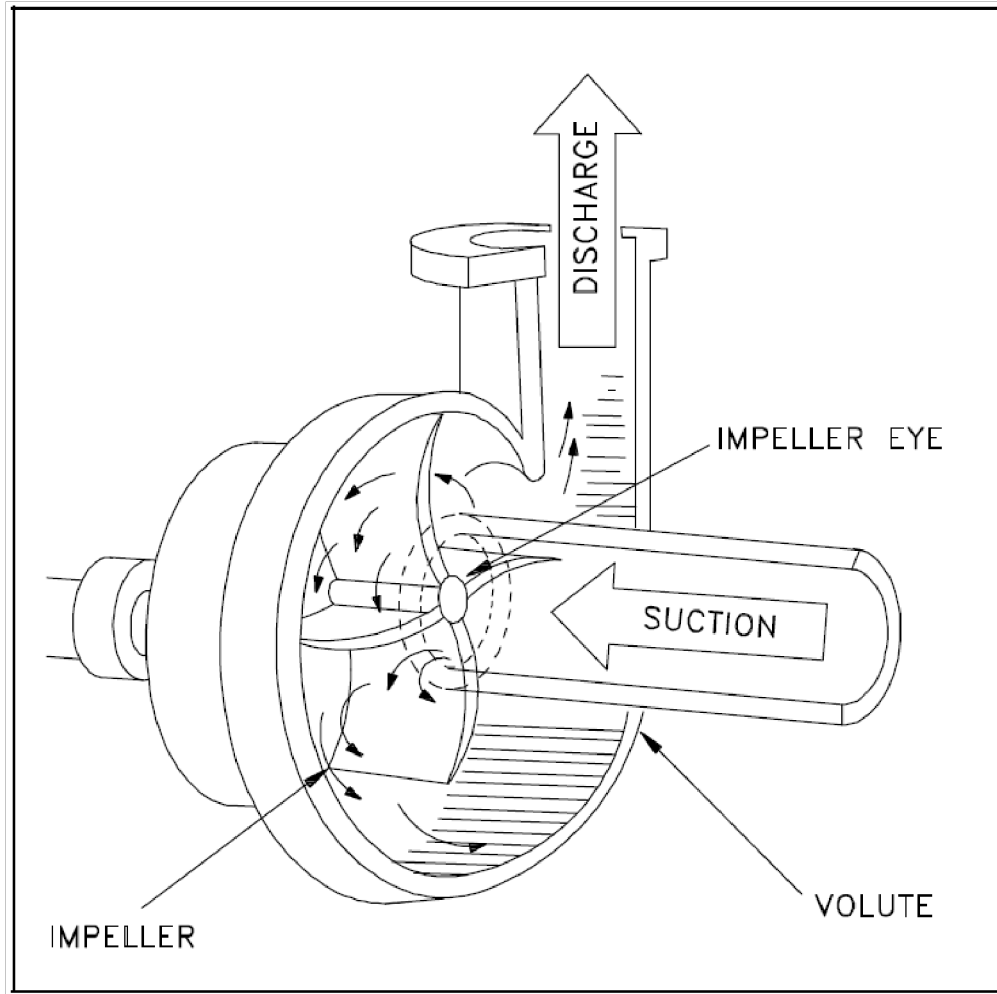

Centrifugal pumps can also be constructed in a manner that results in two distinct volutes, each receiving the liquid that is discharged from a 180° region of the impeller at any given time. Pumps of this type are called double volute pumps (they may also be referred to as split volute pumps). In some applications the double volute minimizes radial forces imparted to the shaft and bearings due to imbalances in the pressure around the impeller. A comparison of single and double volute centrifugal pumps is shown in drawing below.

Standardized RP Junior Task Qualifications Study Guide  
 Lesson RP01.01 Revision 2

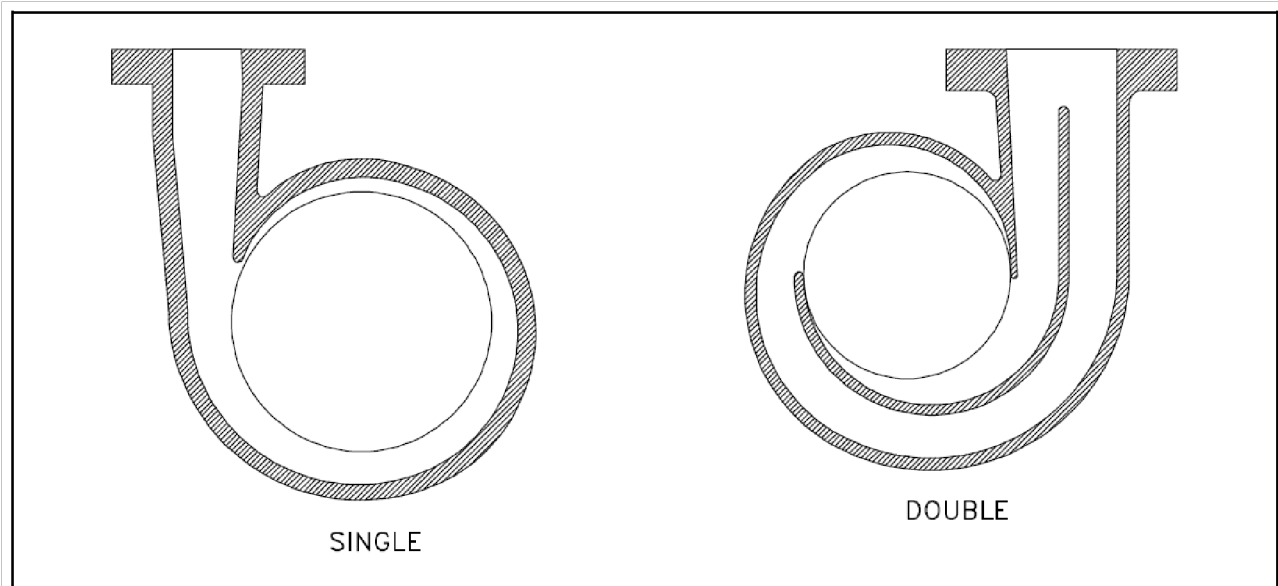

Diffuser

Some centrifugal pumps contain diffusers. A *diffuser* is a set of stationary vanes that surround the impeller. The purpose of the diffuser is to increase the efficiency of the centrifugal pump by allowing a more gradual expansion and less turbulent area for the liquid to reduce in velocity. The diffuser vanes are designed in a manner that the liquid exiting the impeller will encounter an ever-increasing flow area as it passes through the diffuser. This increase in flow area causes a reduction in flow velocity, converting kinetic energy into flow pressure.

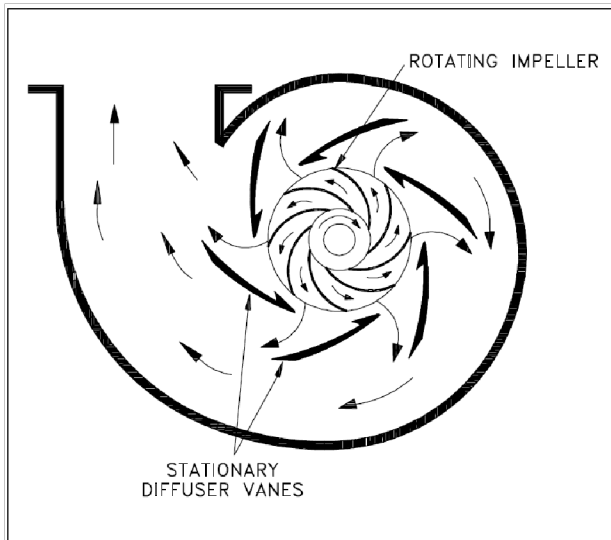

Centrifugal Pump Classification by Flow

Standardized RP Junior Task Qualifications Study Guide  
Lesson RP01.01 Revision 2

Centrifugal pumps can be classified based on the manner in which fluid flows through the pump.

The manner in which fluid flows through the pump is determined by the design of the pump casing and the impeller. The three types of flow through a centrifugal pump are radial flow, axial flow, and mixed flow.

### Radial Flow Pumps

In a radial flow pump, the liquid enters at the center of the impeller and is directed out along the impeller blades in a direction at right angles to the pump shaft. The impeller of a typical radial flow pump and the flow through a radial flow pump are shown in below.

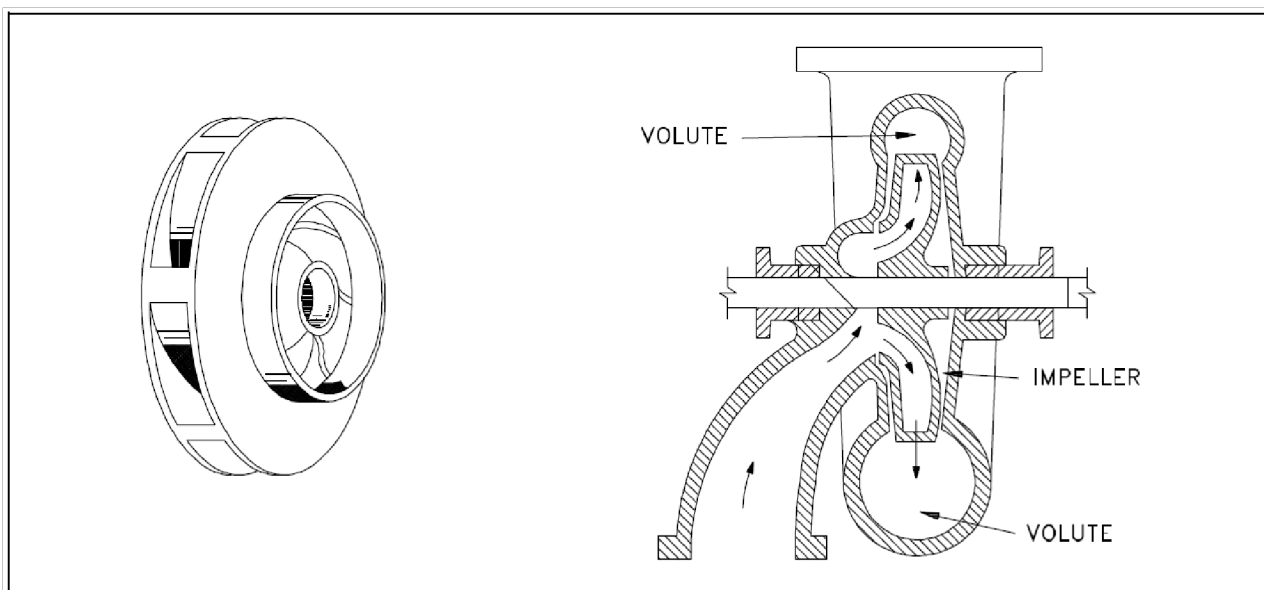

### Axial Flow Pumps

In an axial flow pump, the impeller pushes the liquid in a direction parallel to the pump shaft. Axial flow pumps are sometimes called propeller pumps because they operate essentially the same as the propeller of a boat. The impeller of a typical axial flow pump and the flow through a radial flow pump are shown in below.

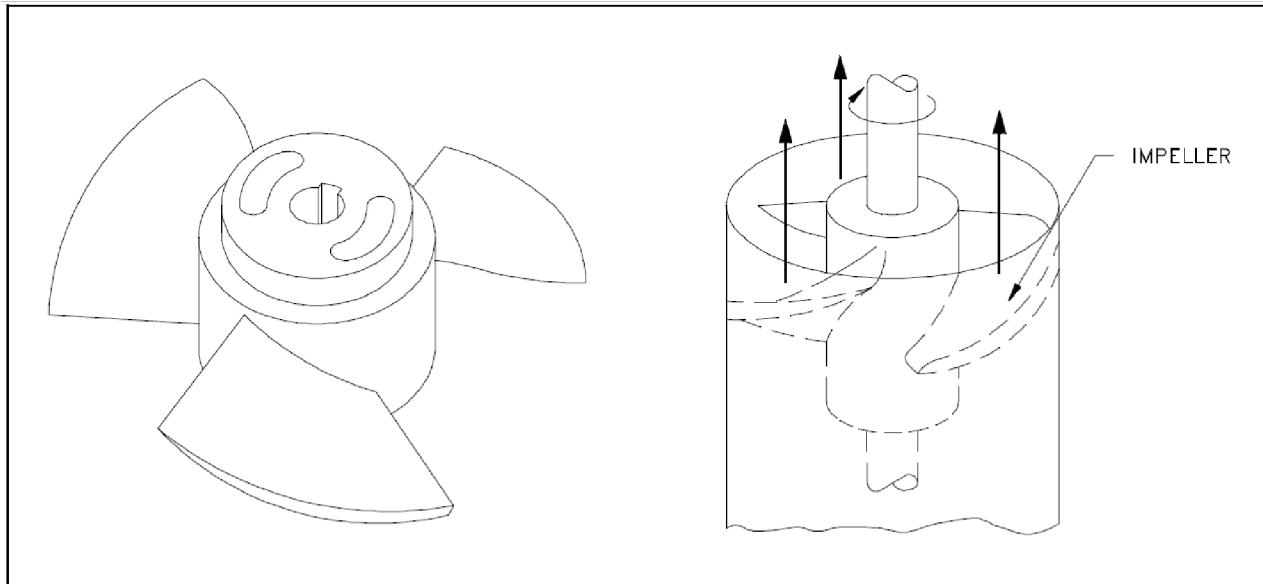

### Multi-Stage Centrifugal Pumps

A centrifugal pump with a single impeller that can develop a differential pressure of more than 150 psid between the suction and the discharge is difficult and costly to design and construct. A more economical approach to developing high pressures with a single centrifugal pump is to include multiple impellers on a common shaft within the same pump casing. Internal channels in the pump casing route the discharge of one impeller to the suction of another impeller. The figure below shows a diagram of the arrangement of the impellers of a four-stage pump. The water enters the pump from the top left and passes through each of the four impellers in series, going from left to right. The water goes from the volute surrounding the discharge of one impeller to the suction of the next impeller.

A *pump stage* is defined as that portion of a centrifugal pump consisting of one impeller and its associated components. Most centrifugal pumps are single-stage pumps, containing only one impeller. A pump containing seven impellers within a single casing would be referred to as a seven-stage pump or, or generally, as a multi-stage pump.

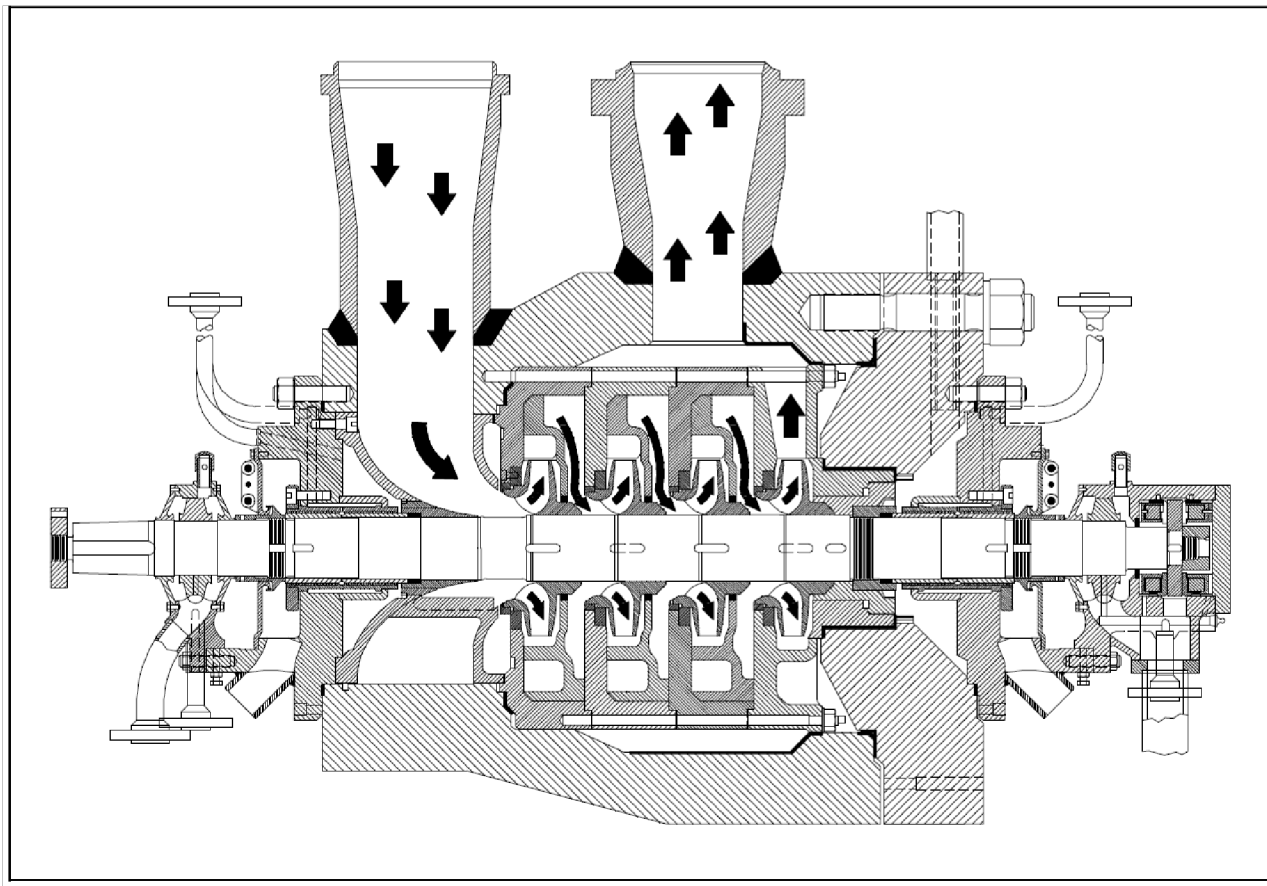

### Positive Displacement pumps

Centrifugal pumps can be classified based on the way fluid flows through the pump.

The way fluid flows through the pump is determined by the design of the pump casing and the impeller. The three types of flow through a centrifugal pump are radial flow, axial flow, and mixed flow.

A positive displacement pump is one in which a definite volume of liquid is delivered for each cycle of pump operation. This volume is constant regardless of the resistance to flow offered by the system the pump is in, provided the capacity of the power unit driving the pump or pump component strength limits are not exceeded. The positive displacement pump delivers liquid in separate volumes with no delivery in between, although a pump having several chambers may have an overlapping delivery among individual chambers, which minimizes this effect.

Standardized RP Junior Task Qualifications Study Guide  
 Lesson RP01.01 Revision 2

A positive displacement pump is one in which a definite volume of liquid is delivered for each cycle of pump operation. This volume is constant regardless of the resistance to flow offered by the system the pump is in, provided the capacity of the power unit driving the pump or pump component strength limits are not exceeded. The positive displacement pump delivers liquid in separate volumes with no delivery in between, although a pump having several chambers may have an overlapping delivery among individual chambers, which minimizes this effect. The positive displacement pump differs from centrifugal pumps, which deliver a continuous flow for any given pump speed and discharge resistance. Positive displacement pumps can be grouped into three basic categories based on their design and operation. The three groups are reciprocating pumps, rotary pumps, and diaphragm pumps.

Principles of Operation, all positive displacement pumps operate on the same basic principle. This principle can be most easily demonstrated by considering a reciprocating positive displacement pump consisting of a single reciprocating piston in a cylinder with a single suction port and a single discharge port as shown below. Check valves in the suction and discharge ports allow flow in only one direction.

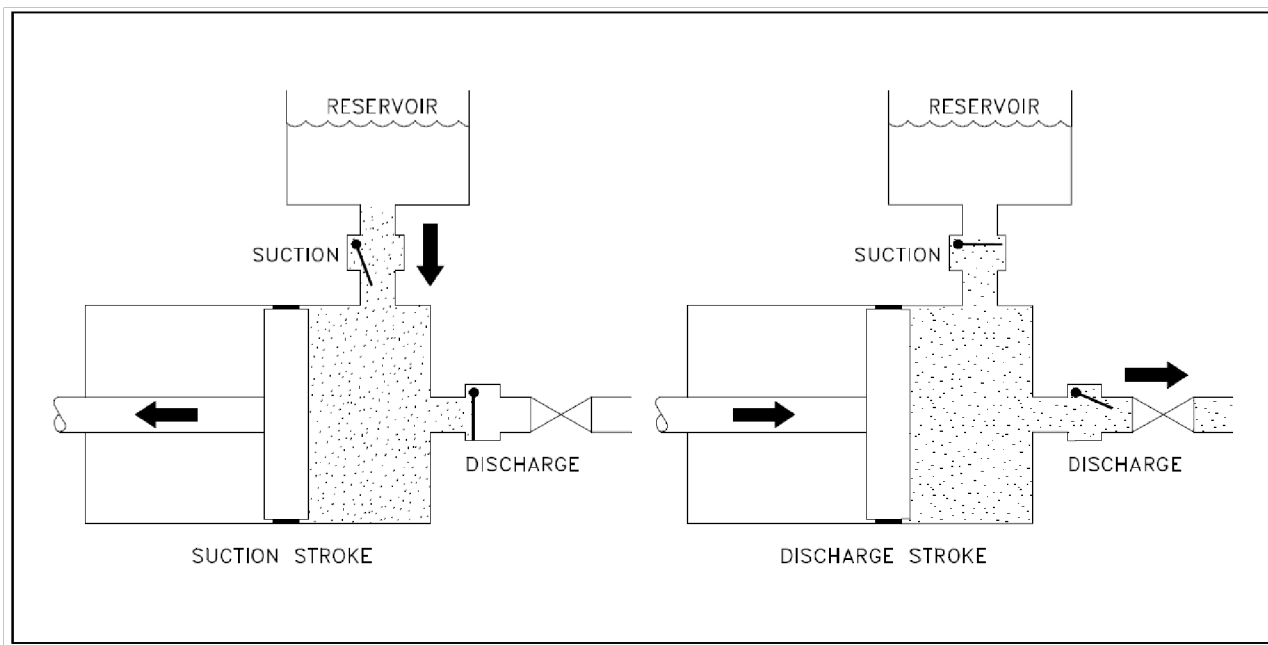

During the suction stroke, the piston moves to the left, causing the check valve in the suction line between the reservoir and the pump cylinder to open and admit water from

### Standardized RP Junior Task Qualifications Study Guide Lesson RP01.01 Revision 2

the reservoir. During the discharge stroke, the piston moves to the right, seating the check valve in the suction line and opening the check valve in the discharge line. The volume of liquid moved by the pump in one cycle (one suction stroke and one discharge stroke) is equal to the change in the liquid volume of the cylinder as the piston moves from its farthest left position to its farthest right position.

#### Reciprocating Pumps

Reciprocating positive displacement pumps are generally categorized in four ways: direct-acting or indirect-acting; simplex or duplex; single-acting or double-acting; and power pumps.

#### Direct-Acting and Indirect-Acting Pumps

Some reciprocating pumps are powered by prime movers that also have reciprocating motion, such as a reciprocating pump powered by a reciprocating steam piston. The piston rod of the steam piston may be directly connected to the liquid piston of the pump, or it may be indirectly connected with a beam or linkage. *Direct-acting* pumps have a plunger on the liquid (pump) end that is directly driven by the pump rod (also the piston rod or extension thereof) and carries the piston of the power end. *Indirect-acting* pumps are driven by means of a beam or linkage connected to and actuated by the power piston rod of a separate reciprocating engine.

#### Simplex and Duplex Pumps

A *simplex* pump, sometimes referred to as a single pump, is a pump having a single liquid (pump) cylinder. A *duplex* pump is the equivalent of two simplex pumps placed side by side on the same foundation. The driving of the pistons of a duplex pump is arranged in such a manner that when one piston is on its upstroke the other piston is on its downstroke, and vice versa. This arrangement doubles the capacity of the duplex pump compared to a simplex pump of comparable design.

#### Single-Acting and Double-Acting Pumps

A *single-acting* pump is one that takes a suction, filling the pump cylinder on the stroke in only one direction, called the suction stroke, and then forces the liquid out of the cylinder on the return stroke, called the discharge stroke. A *double-acting* pump is one that, as it fills one end of the liquid cylinder, is discharging liquid from

Standardized RP Junior Task Qualifications Study Guide  
Lesson RP01.01 Revision 2

the other end of the cylinder. On the return stroke, the end of the cylinder just emptied is filled, and the end just filled is emptied. One possible arrangement for single-acting and double-acting pumps is shown below.

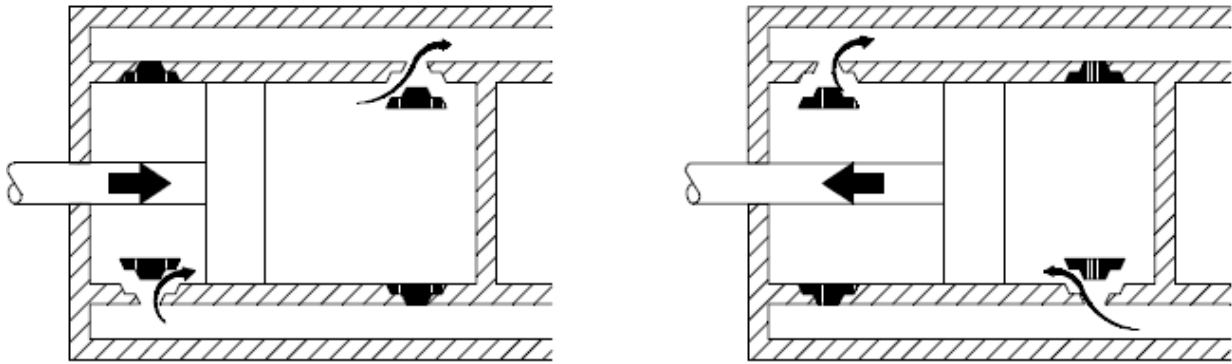

DOUBLE ACTING

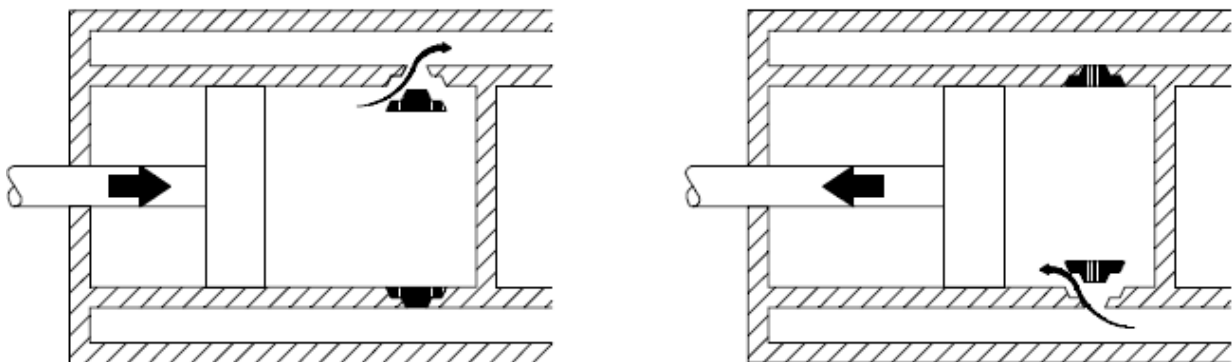

SINGLE ACTING

Standardized RP Junior Task Qualifications Study Guide  
Lesson RP01.01 Revision 2

EO: 1.64 Identify the type of valve, the major components of the valve and packing assembly, given an unlabeled cross-sectional diagram of the valve

Because of the diversity of the types of systems, fluids, and environments in which valves must operate, a vast array of valve types has been developed. Examples of the common types are the globe valve, gate valve, ball valve, plug valve, butterfly valve, diaphragm valve, check valve, pinch valve, and safety valve. Each type of valve has been designed to meet specific needs. Some valves are capable of throttling flow, other valve types can only stop flow, others work well in corrosive systems, and others handle high pressure fluids. Each valve type has certain inherent advantages and disadvantages. Understanding these differences and how they affect the valve's application or operation is necessary for the successful operation of a facility.

Although all valves have the same basic components and function to control flow in some fashion, the method of controlling the flow can vary dramatically. In general, there are four methods of controlling flow through a valve.

- Move a disc or plug into or against an orifice (for example, globe or needle type valve).
- Slide a flat, cylindrical, or spherical surface across an orifice (for example, gate and plug valves).
- Rotate a disc or ellipse about a shaft extending across the diameter of an orifice (for example, a butterfly or ball valve).
- Move a flexible material into the flow passage (for example, diaphragm and pinch valves).

Each method of controlling flow has characteristics that makes it the best choice for a given application of function.

### Valves

A valve is a mechanical device that controls the flow of fluid and pressure within a system or process. A valve controls system or process fluid flow and pressure by performing any of the following functions:

- Stopping and starting fluid flow
- Varying (throttling) the amount of fluid flow
- Controlling the direction of fluid flow
- Regulating downstream system or process pressure

### Standardized RP Junior Task Qualifications Study Guide Lesson RP01.01 Revision 2

- Relieving component or piping over pressure

There are many valve designs and types that satisfy one or more of the functions identified above. A multitude of valve types and designs safely accommodate a wide variety of industrial applications.

Regardless of type, all valves have the following basic parts: the body, bonnet, trim (internal elements), actuator, and packing. The basic parts of a valve are illustrated on page 162.

#### Valve Body

The *body*, sometimes called the shell, is the primary pressure boundary of a valve. It serves as the principal element of a valve assembly because it is the framework that holds everything together.

The body, the first pressure boundary of a valve, resists fluid pressure loads from connecting piping. It receives inlet and outlet piping through threaded, bolted, or welded joints.

Valve bodies are cast or forged into a variety of shapes. Although a sphere or a cylinder would theoretically be the most economical shape to resist fluid pressure when a valve is open, there are many other considerations.

For example, many valves require a partition across the valve body to support the seat opening, which is the throttling orifice. With the valve closed, loading on the body is difficult to determine. The valve end connections also distort loads on a simple sphere and more complicated shapes. Ease of manufacture, assembly, and costs are additional important considerations. Hence, the basic form of a valve body typically is not spherical, but ranges from simple block shapes to highly complex shapes in which the bonnet, a removable piece to make assembly possible, forms part of the pressure resisting body.

Narrowing of the fluid passage (venturi effect) is also a common method for reducing the overall size and cost of a valve. In other instances, large ends are added to the valve for connection into a larger line.

#### Valve Bonnet

The cover for the opening in the valve body is the *bonnet*. In some designs, the body itself is split into two sections that bolt together. Like valve bodies, bonnets vary in design. Some bonnets function simply as valve covers, while others support valve internals and accessories such as the stem, disk, and actuator.

The bonnet is the second principal pressure boundary of a valve. It is cast or forged of the same material as the body and is connected to the body by a threaded, bolted, or

### Standardized RP Junior Task Qualifications Study Guide Lesson RP01.01 Revision 2

welded joint. In all cases, the attachment of the bonnet to the body is considered a pressure boundary. This means that the weld joint or bolts that connect the bonnet to the body are pressure-retaining parts. Valve bonnets, although a necessity for most valves, represent a cause for concern. Bonnets can complicate the manufacture of valves, increase valve size, represent a significant cost portion of valve cost, and are a source for potential leakage.

#### Valve Trim

The internal elements of a valve are collectively referred to as a valve's *trim*. The trim typically includes a *disk*, *seat*, *stem*, and *sleeves* needed to guide the stem. A valve's performance is determined by the disk and seat interface and the relation of the disk position to the seat. Because of the trim, basic motions and flow control are possible. In rotational motion trim designs, the disk slides closely past the seat to produce a change in flow opening. In linear motion trim designs, the disk lifts perpendicularly away from the seat so that an annular orifice appears.

#### Disk and Seat

For a valve having a bonnet, the disk is the third primary principal pressure boundary. The disk provides the capability for permitting and prohibiting fluid flow. With the disk closed, full system pressure is applied across the disk if the outlet side is depressurized. For this reason, the disk is a pressure-retaining part. Disks are typically forged and, in some designs, hard surfaced to provide good wear characteristics. A fine surface finish of the seating area of a disk is necessary for good sealing when the valve is closed. Most valves are named, in part, according to the design of their disks. The seat or seal rings provide the seating surface for the disk. In some designs, the body is machined to serve as the seating surface and seal rings are not used. In other designs, forged seal rings are threaded or welded to the body to provide the seating surface. To improve the wear-resistance of the seal rings, the surface is often hard-faced by welding and then machining the contact surface of the seal ring. A fine surface finish of the seating area is necessary for good sealing when the valve is closed. Seal rings are not usually considered pressure boundary parts because the body has sufficient wall thickness to withstand design pressure without relying upon the thickness of the seal rings.

#### Stem

The *stem*, which connects the actuator and disk, is responsible for positioning the disk. Stems are typically forged and connected to the disk by threaded or welded

Standardized RP Junior Task Qualifications Study Guide  
 Lesson RP01.01 Revision 2

joints. For valve designs requiring stem packing or sealing to prevent leakage, a fine surface finish of the stem in the area of the seal is necessary. Typically, a stem is not considered a pressure boundary part. Connection of the disk to the stem can allow some rocking or rotation to ease the positioning of the disk on the seat. Alternately, the stem may be flexible enough to let the disk position itself against the seat. However, constant fluttering or rotation of a flexible or loosely connected disk can destroy the disk or its connection to the stem. Two types of valve stems are rising stems and non-rising stems. Illustrated in Figures 2 and 3, these two types of stems are easily distinguished by observation. For a rising stem valve, the stem will rise above the actuator as the valve is opened. This occurs because the stem is threaded and mated with the bushing threads of a yoke that is an integral part of, or is mounted to, the bonnet.

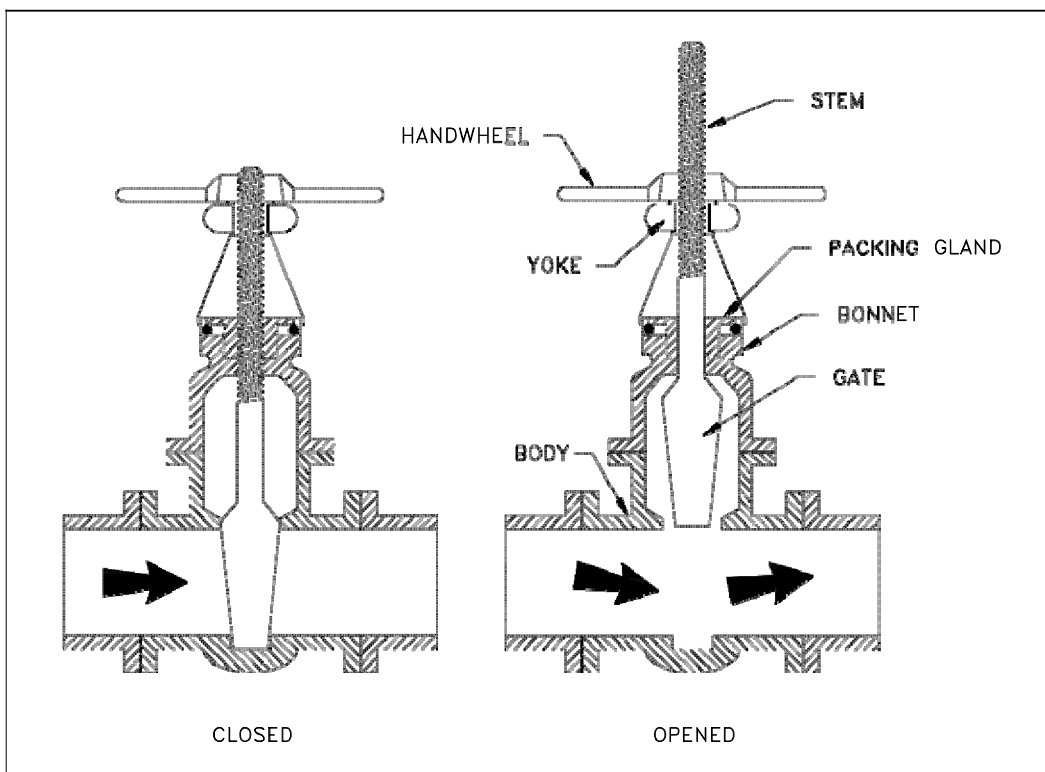

Rising Stem

Standardized RP Junior Task Qualifications Study Guide  
 Lesson RP01.01 Revision 2

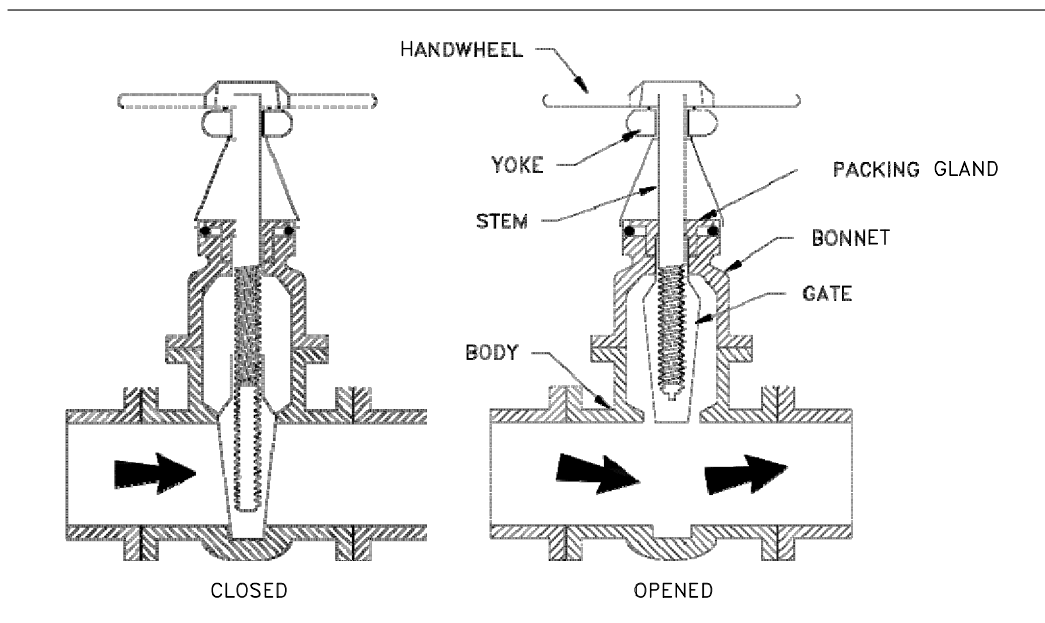

Non-rising Stem

### Valve Actuator

The *actuator* operates the stem and disk assembly. An actuator may be a manually operated hand wheel, manual lever, motor operator, solenoid operator, pneumatic operator, or hydraulic ram. In some designs, the actuator is supported by the bonnet. In other designs, a yoke mounted to the bonnet supports the actuator. Except for certain hydraulically controlled valves, actuators are outside of the pressure boundary. Yokes, when used, are always outside of the pressure boundary.

### Valve Packing

Most valves use some form of packing to prevent leakage from the space between the stem and the bonnet. *Packing* is commonly a fibrous material (such as flax) or another compound (such as Teflon) that forms a seal between the internal parts of a valve and the outside where the stem extends through the body. Valve packing must be properly compressed to prevent fluid loss and damage to the valve's stem. If a valve's packing is too loose, the valve will leak, which is a safety hazard. If the packing is too tight, it will impair the movement and possibly damage the stem.

Standardized RP Junior Task Qualifications Study Guide  
Lesson RP01.01 Revision 2

Introduction to the types of valves

Figure 1: Basic Parts of a Valve

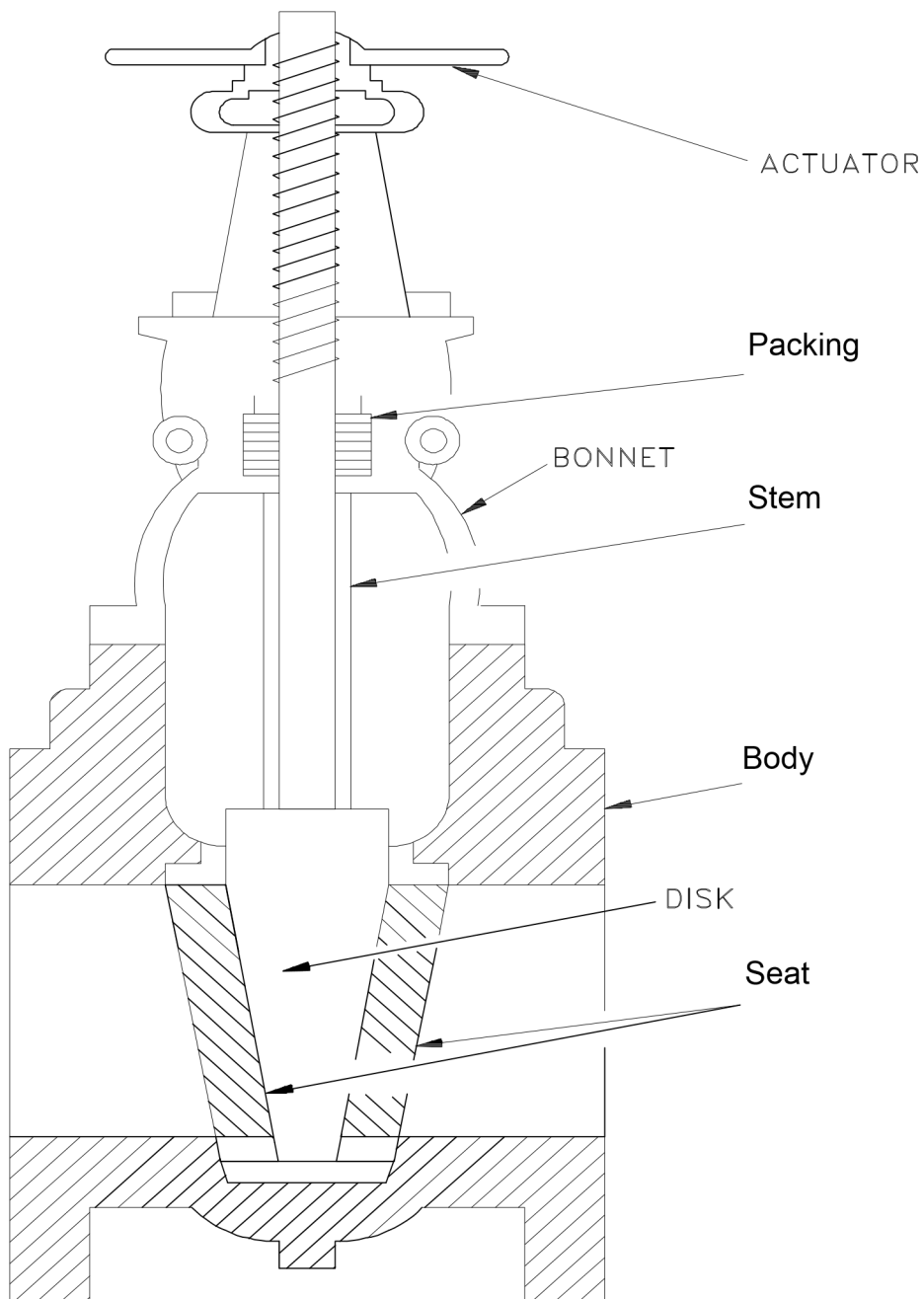

Types of Valves

Standardized RP Junior Task Qualifications Study Guide  
Lesson RP01.01 Revision 2

## Gate Valves

A *gate* valve is a linear motion valve used to start or stop fluid flow; however, it does not regulate or throttle flow. The name gate is derived from the appearance of the disk in the flow stream. The picture on the next page illustrates a gate valve.

The disk of a gate valve is completely removed from the flow stream when the valve is fully open. This characteristic offers virtually no resistance to flow when the valve is open. Hence, there is little pressure drop across an open gate valve. When the valve is fully closed, a disk-to-seal ring contact surface exists for 360°, and good sealing is provided. With the proper mating of a disk to the seal ring, very little or no leakage occurs across the disk when the gate valve is closed.

On opening the gate valve, the flow path is enlarged in a highly nonlinear manner with respect to percent of opening. This means that flow rate does not change evenly with stem travel. Also, a partially open gate disk tends to vibrate from the fluid flow. Most of the flow change occurs near shutoff with a relatively high fluid velocity causing disk and seat wear and eventual leakage if used to regulate flow. For these reasons, gate valves are not used to regulate or throttle flow.

A gate valve can be used for a wide variety of fluids and provides a tight seal when closed. The major disadvantages to the use of a gate valve are:

- It is not suitable for throttling applications.
- It is prone to vibration in the partially open state.
- It is more subject to seat and disk wear than a globe valve.
- Repairs, such as lapping and grinding, are generally more difficult to accomplish.

Standardized RP Junior Task Qualifications Study Guide  
Lesson RP01.01 Revision 2

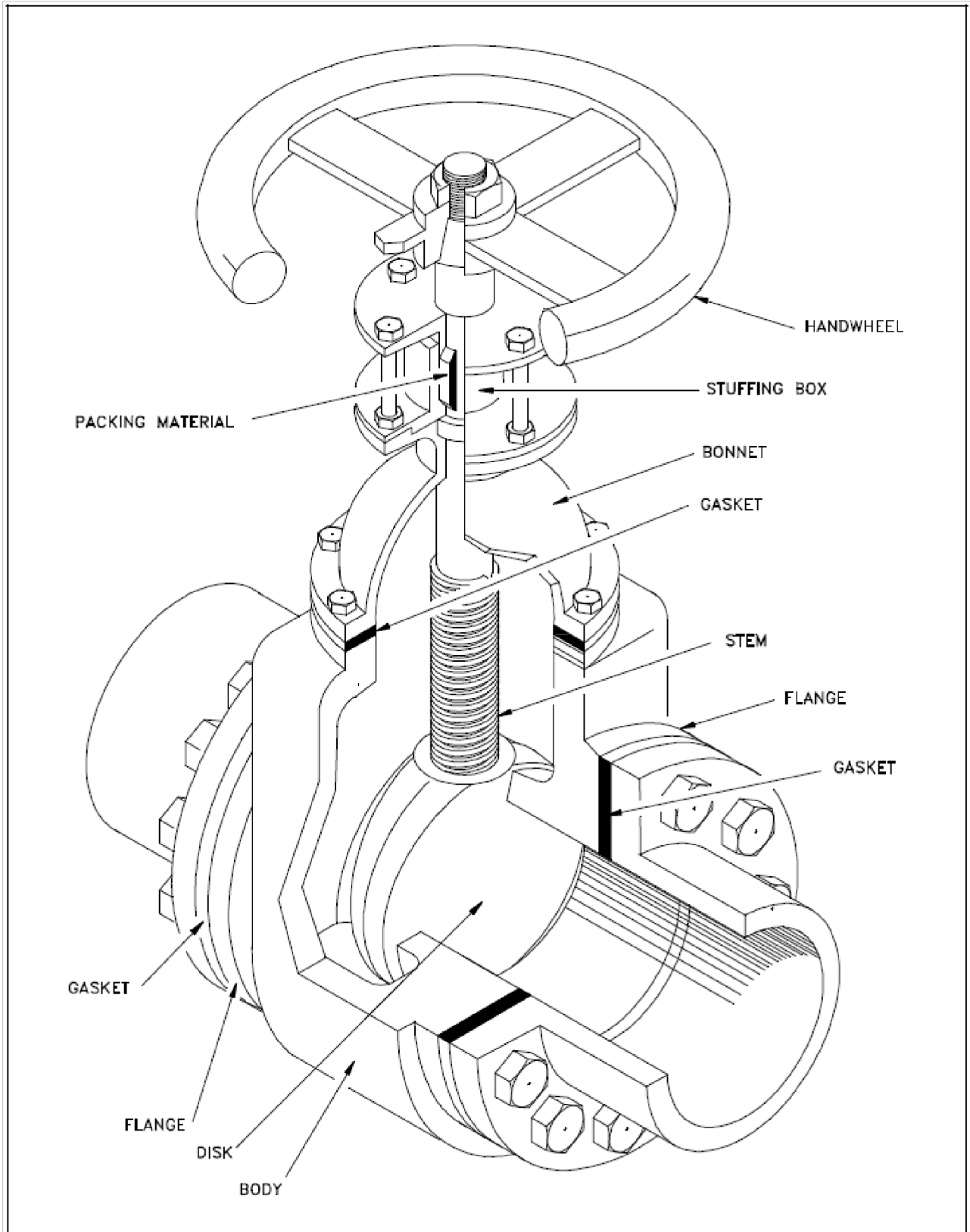

**Standardized RP Junior Task Qualifications Study Guide**  
**Lesson RP01.01 Revision 2**

Globe Valves

A globe valve is a linear motion valve used to stop, start, and regulate fluid flow. A Z-body globe valve is illustrated on the following page.

As shown in the illustration, the globe valve disk can be totally removed from the flow path, or it can completely close the flow path. The essential principle of globe valve operation is the perpendicular movement of the disk away from the seat. This causes the annular space between the disk and seat ring to gradually close as the valve is closed. This characteristic gives the globe valve good throttling ability, which permits its use in regulating flow.

Therefore, the globe valve may be used for both stopping and starting fluid flow and for regulating flow. When compared to a gate valve, a globe valve generally yields much less seat leakage. This is because the disk-to-seat ring contact is more at right angles, which permits the force of closing to tightly seat the disk.

Globe valves can be arranged so that the disk closes against or in the same direction of fluid flow. When the disk closes against the direction of flow, the kinetic energy of the fluid impedes closing but aids opening of the valve. When the disk closes in the same direction of flow, the kinetic energy of the fluid aids closing but impedes opening. This characteristic is preferable to other designs when quick-acting stop valves are necessary.

Globe valves also have drawbacks. The most evident shortcoming of the simple globe valve is the high head loss from two or more right angle turns of flowing fluid. Obstructions and discontinuities in the flow path led to head loss. In a large high-pressure line, the fluid dynamic effects from pulsations, impacts, and pressure drops can damage trim, stem packing, and actuators. In addition, large valve sizes require considerable power to operate and are especially noisy in high pressure applications.

Other drawbacks of globe valves are the large openings necessary for disk assembly, heavier weight than other valves of the same flow rating, and the cantilevered mounting of the disk to the stem.

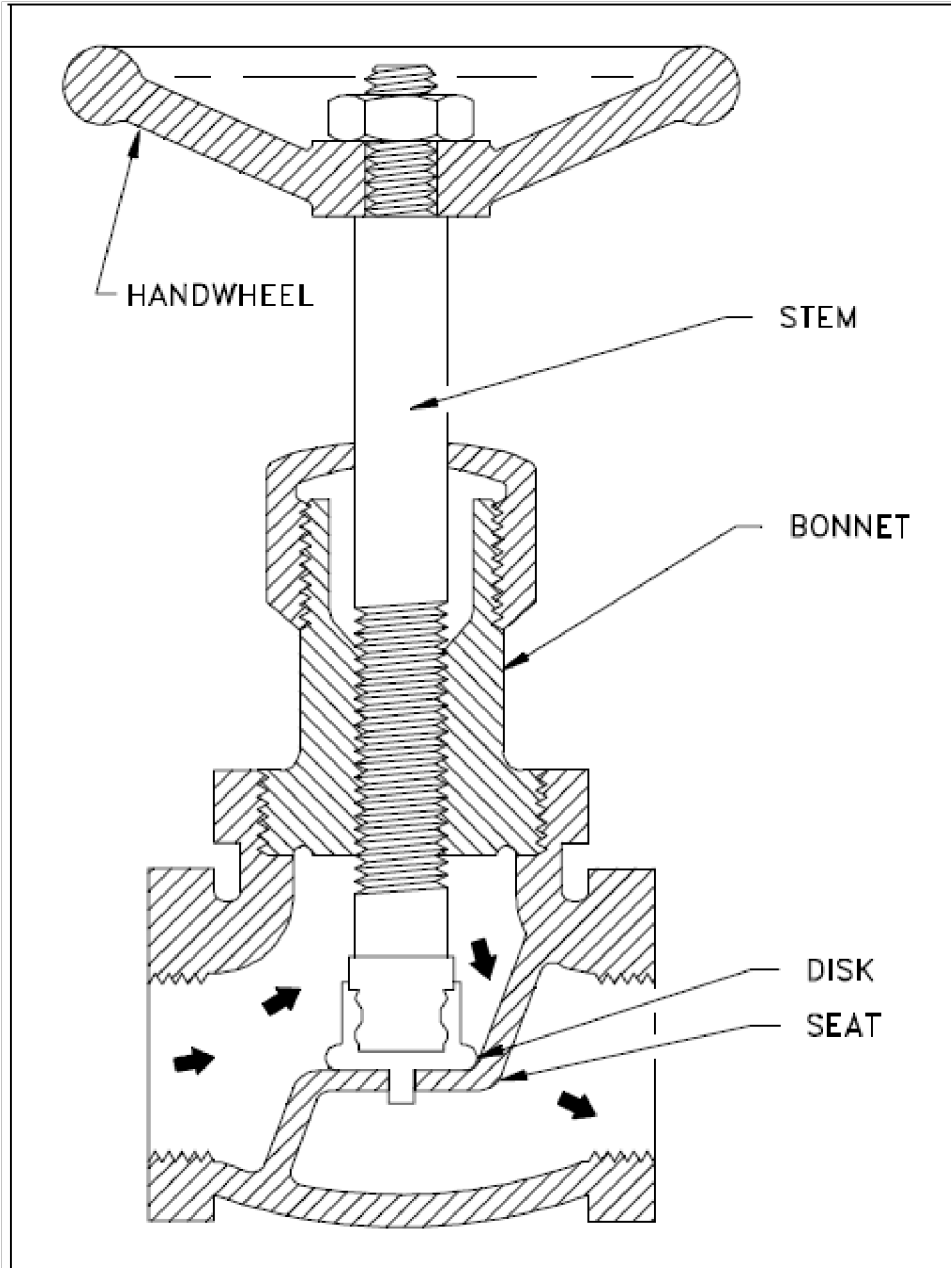

Z-Body Globe Valve

Angle Globe Valve

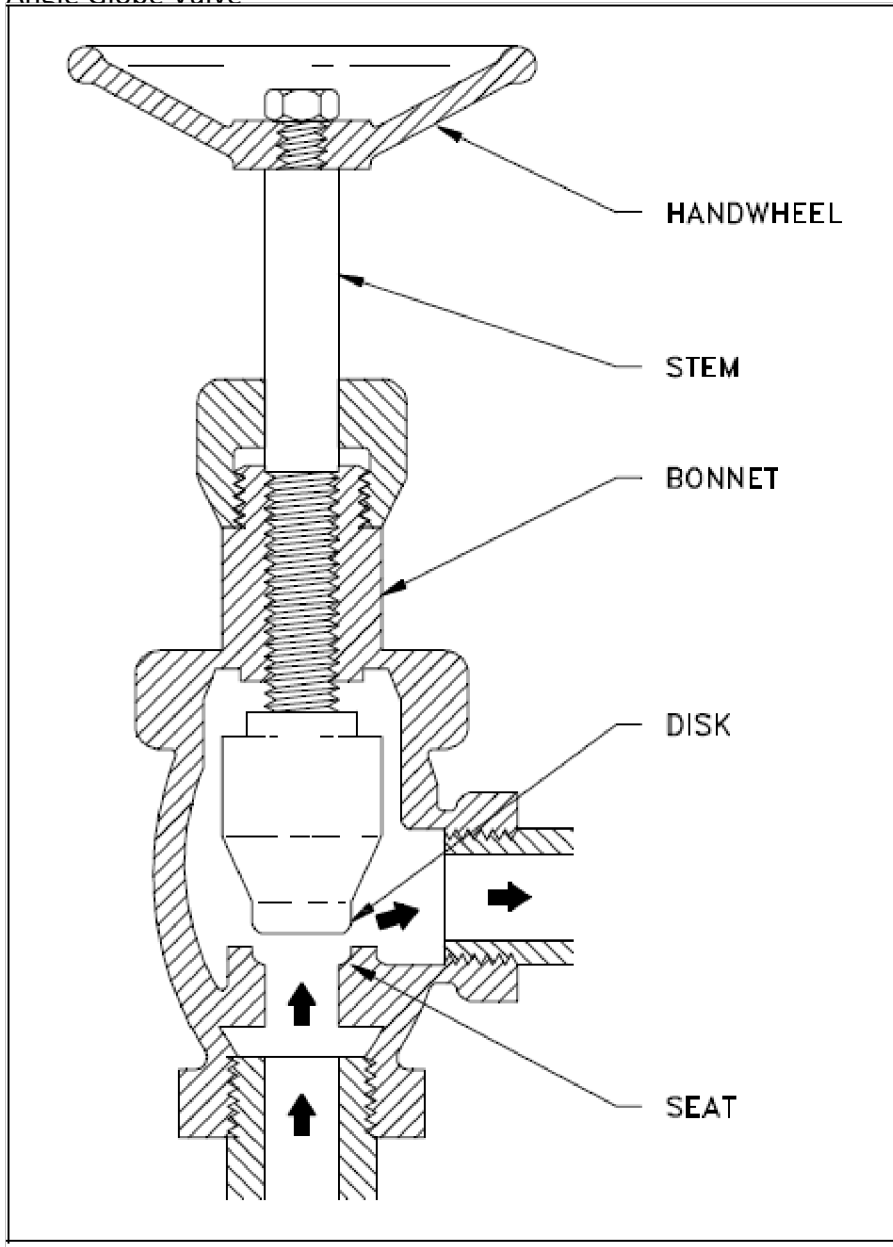

Plug Valves

Standardized RP Junior Task Qualifications Study Guide  
Lesson RP01.01 Revision 2

A plug valve is a rotational motion valve used to stop or start fluid flow. The name is derived from the shape of the disk, which resembles a plug. A plug valve is shown below. The simplest form of a plug valve is the petcock. The body of a plug valve is machined to receive the tapered or cylindrical plug. The disk is a solid plug with a bored passage at a right angle to the longitudinal axis of the plug.

In the open position, the passage in the plug lines up with the inlet and outlet ports of the valve. Plug Valve body. When the plug is turned 90° from the open position, the solid part of the plug blocks the ports and stops fluid flow.

Plug valves are available in either a lubricated or non-lubricated design and with a variety of styles of port openings through the plug as well as a number of plug designs.

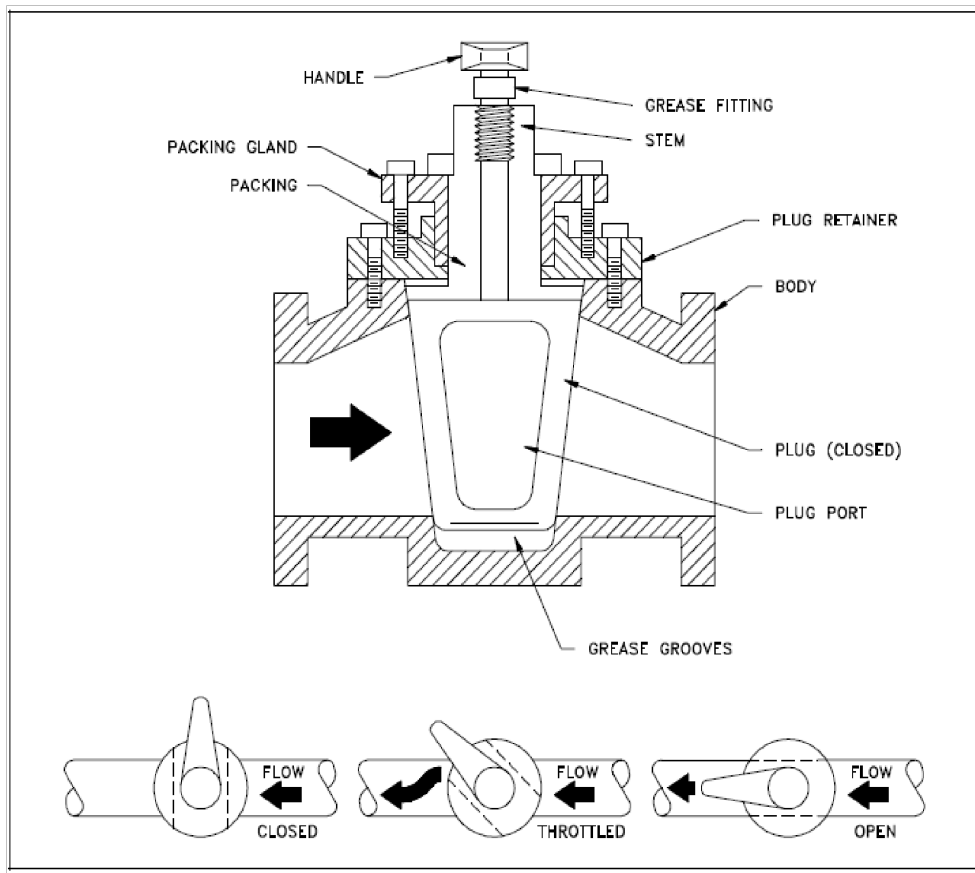

Reducing Valves

Standardized RP Junior Task Qualifications Study Guide  
 Lesson RP01.01 Revision 2

Reducing valves automatically reduce supply pressure to a preselected pressure as long as the supply pressure is at least as high as the selected pressure. As illustrated below, the principal parts of the reducing valve are the main valve; an upward-seating valve that has a piston on top of its valve stem, an upward-seating auxiliary (or controlling) valve, a controlling diaphragm, and an adjusting spring and screw.

Check Valve

Check valves are designed to prevent the reversal of flow in a piping system. These valves are activated by the flowing material in the pipeline. The pressure of the fluid passing through the system opens the valve, while any reversal of flow will close the valve. Closure is accomplished by the weight of the check mechanism, by back pressure, by a spring, or by a combination of these means. The general types of check valves are swing, tilting-disk, piston, butterfly, and stop.

Swing Check Valves

A swing check valve is illustrated below. The valve allows full, unobstructed flow and automatically closes as pressure decreases. These valves are fully closed when the flow reaches zero and prevent back flow. Turbulence and pressure drop within the valve are very low.

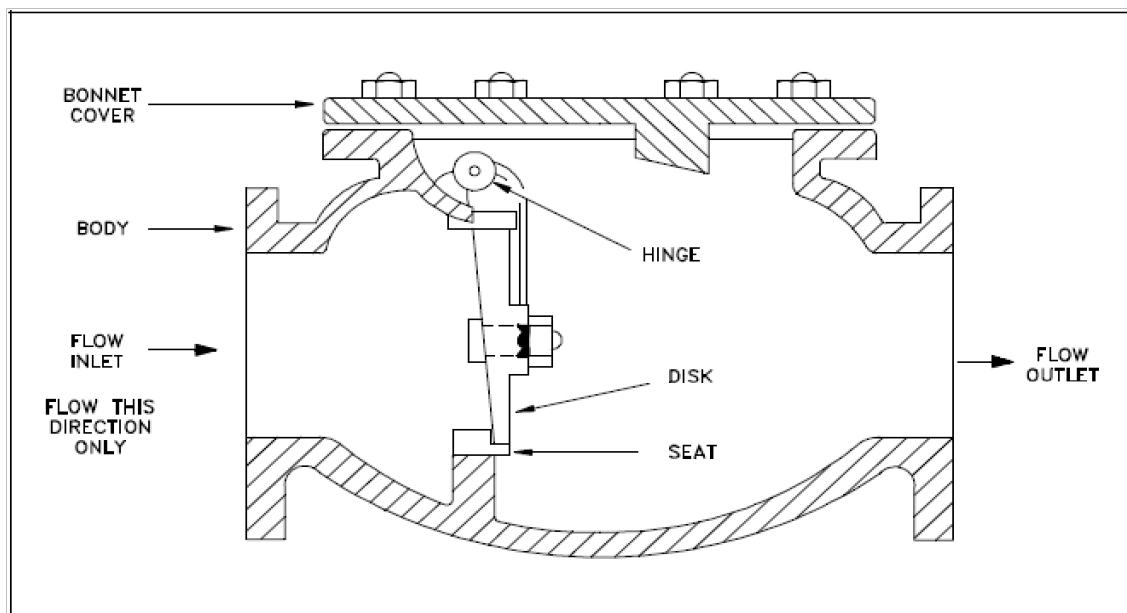

A swing check valve is normally recommended for use in systems employing gate valves because of the low pressure drop across the valve. Swing check valves are available in either Y-pattern or straight body design. A straight check valve is illustrated above. In either style, the disk and hinge are suspended from the body

**Standardized RP Junior Task Qualifications Study Guide**  
**Lesson RP01.01 Revision 2**

by means of a hinge pin. Seating is either metal-to-metal or metal seat to composition disk. Composition disks are usually recommended for services where dirt or other particles may be present in the fluid, where noise is objectionable, or where positive shutoff is required.

Straight body swing check valves contain a disk that is hinged at the top. The disk seals against the seat, which is integral with the body. This type of check valve usually has replaceable seat rings. The seating surface is placed at a slight angle to permit easier opening at lower pressures, more positive sealing, and less shock when closing under higher pressures. Swing check valves are usually installed in conjunction with gate valves because they provide relatively free flow. They are recommended for lines having low velocity flow and should not be used on lines with pulsating flow when the continual flapping or pounding would be destructive to the seating elements. This condition can be partially corrected by using an external lever and weight.

#### Lift Check Valves

A lift check valve, illustrated below, is commonly used in piping systems in which globe valves are being used as a flow control valve. They have similar seating arrangements as globe valves.

Standardized RP Junior Task Qualifications Study Guide  
 Lesson RP01.01 Revision 2

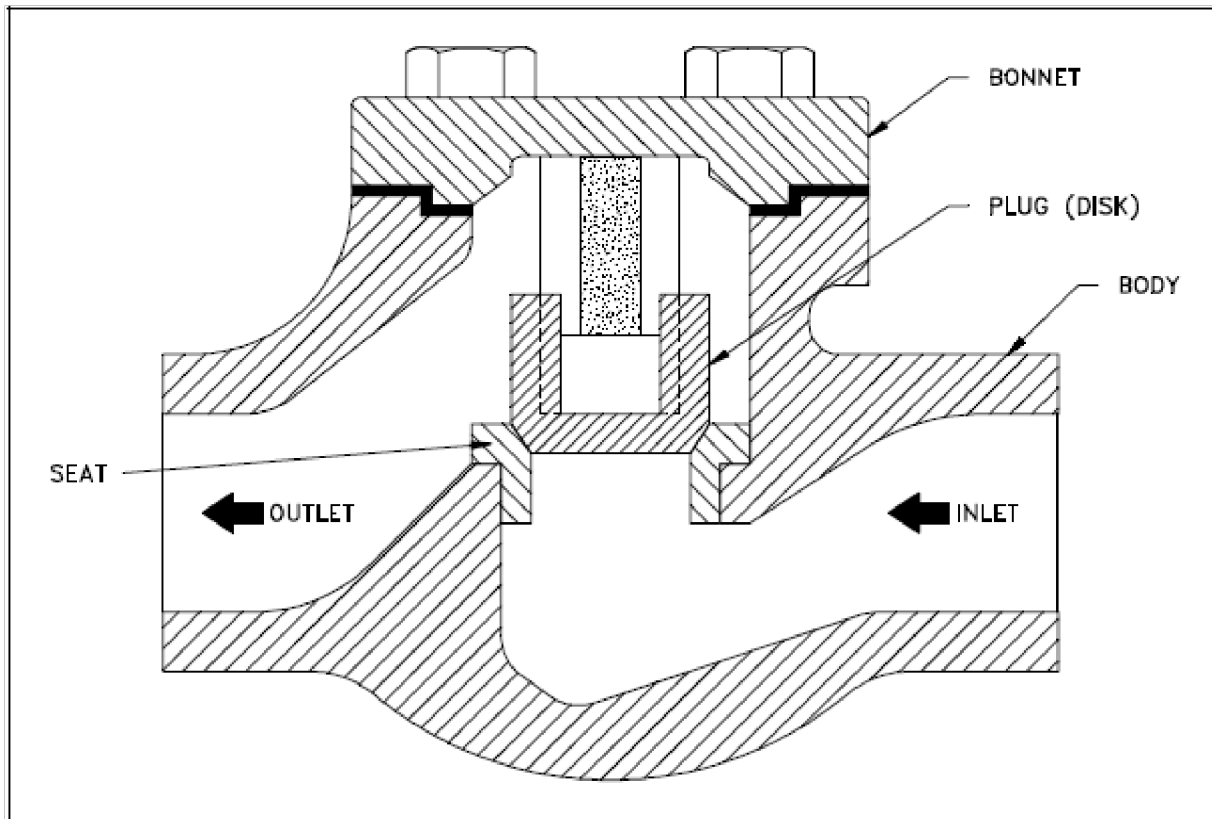

Lift check valves are suitable for installation in horizontal or vertical lines with upward flow. They are recommended for use with steam, air, gas, water, and on vapor lines with high flow velocities. These valves are available in three body patterns: horizontal, angle, and vertical.

Flow to lift check valves must always enter below the seat. As the flow enters, the disk or ball is raised within guides from the seat by the pressure of the upward flow. When the flow stops or reverses, the disk or ball is forced onto the seat of the valve by both the backflow and gravity.

Some types of lift check valves may be installed horizontally. In this design, the ball is suspended by a system of guide ribs. This type of check valve design is generally employed in plastic check valves.

The seats of metallic body lift check valves are either integral with the body or contain renewable seat rings. Disk construction is similar to the disk construction of globe valves with either metal or composition disks. Metal disk and seat valves can be reground using the same techniques as is used for globe valves.

Standardized RP Junior Task Qualifications Study Guide  
 Lesson RP01.01 Revision 2

Relief and Safety Valves

Relief and safety valves prevent equipment damage by relieving accidental over-pressurization of fluid systems. The main difference between a relief valve and a safety valve is the extent of opening at the setpoint pressure.

A relief valve, illustrated in below, gradually opens as the inlet pressure increases above the setpoint. A relief valve opens only as necessary to relieve the over-pressure condition.

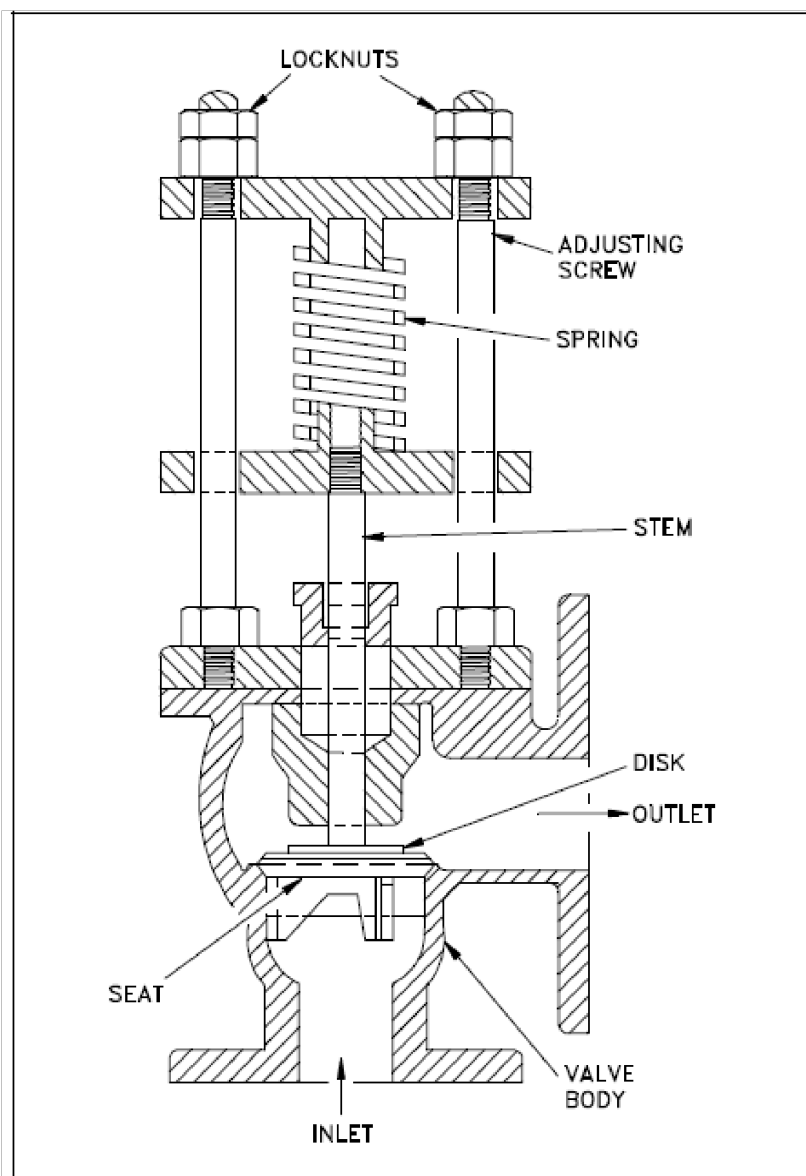

Standardized RP Junior Task Qualifications Study Guide  
 Lesson RP01.01 Revision 2

A safety valve, illustrated below, rapidly pops fully open as soon as the pressure setting is reached. A safety valve will stay fully open until the pressure drops below a reset pressure. The reset pressure is lower than the actuating pressure setpoint. The difference between the actuating pressure setpoint and the pressure at which the safety valve resets is called *blowdown*.

Blowdown is expressed as a percentage of the actuating pressure setpoint. Relief valves are typically used for incompressible fluids such as water or oil. Safety valves are typically used for compressible fluids such as steam or other gases. Safety valves can often be distinguished by the presence of an external lever at the top of the valve body, which is used as an operational check.

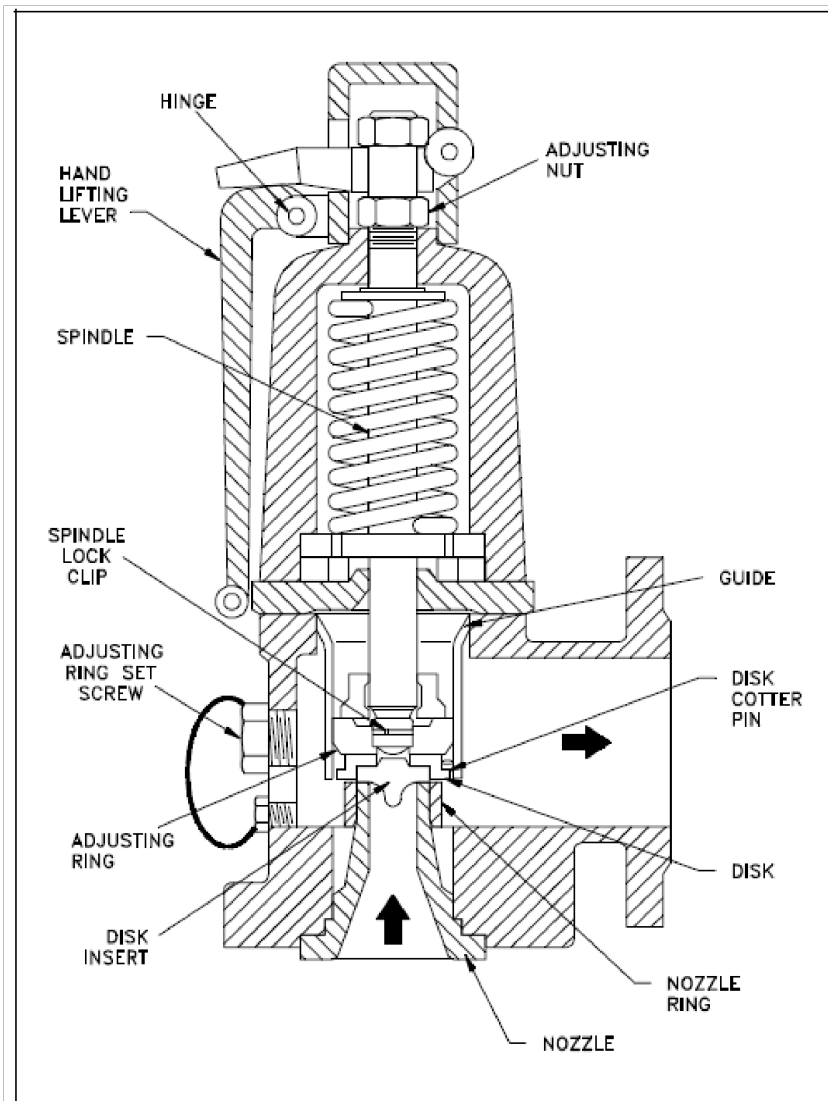

### Standardized RP Junior Task Qualifications Study Guide Lesson RP01.01 Revision 2

As indicated in above, system pressure provides a force that is attempting to push the disk of the safety valve off its seat. Spring pressure on the stem is forcing the disk onto the seat.

At the pressure determined by spring compression, system pressure overcomes spring pressure, and the relief valve opens. As system pressure is relieved, the valve closes when spring pressure again overcomes system pressure. Most relief and safety valves open against the force of a compression spring. The pressure setpoint is adjusted by turning the adjusting nuts on top of the yoke to increase or decrease the spring compression.

Standardized RP Junior Task Qualifications Study Guide  
Lesson RP01.01 Revision 2

EO: 1.65 Explain why the innermost packing ring inside a leaking radioactive system valve will generally exhibit the highest dose rate and contamination levels

What is packing?

Most valves use some form of packing to prevent leakage from the space between the stem and the bonnet. *Packing* is commonly a fibrous material (such as flax) or another compound (such as Teflon) that forms a seal between the internal parts of a valve and the outside where the stem extends through the body.

Valve packing must be properly compressed to prevent fluid loss and damage to the valve's stem. If a valve's packing is too loose, the valve will leak, which is a safety hazard. If the packing is too tight, it will impair the movement and possibly damage the stem.

Based on the drawing below, which ring of packing is in direct contact with the radioactive system?

Why would you expect this ring of packing to have the highest dose?

Figure 1: Basic Parts of a Valve

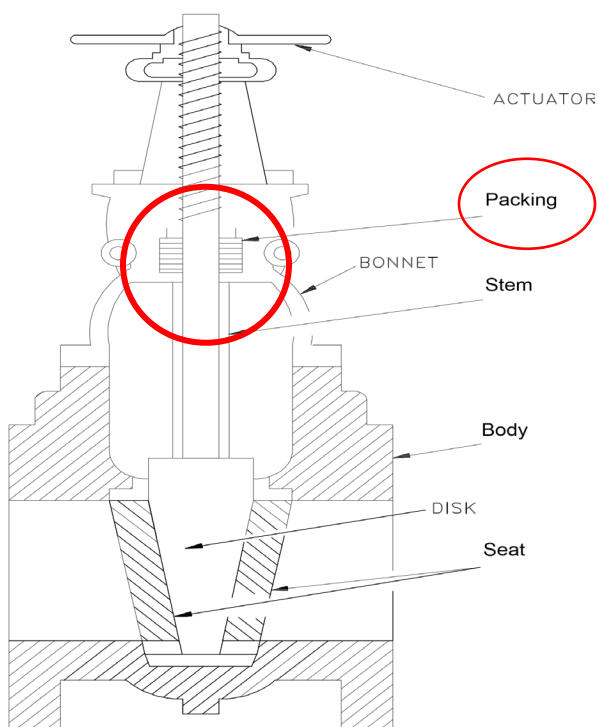

Standardized RP Junior Task Qualifications Study Guide  
 Lesson RP01.01 Revision 2

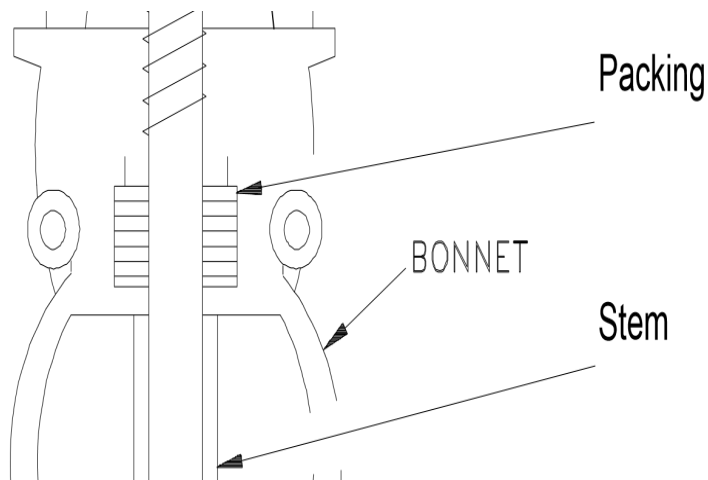

As shown in the drawings above, the packing is located around the stem of the valve to keep the fluid in the system. A number of rings of packing are located along the valve stem and held in place by a packing gland. The ring that is closest to the fluid would be the first ring to come in contact with the fluid, and act as a filter to remove particulate located in the fluid. Therefore, the first ring would be exposed and filter the particulate. As the fluid past through the other rings, any additional particulate should be captured. As packing rings are removed and surveyed the radioactivity level should increase with the most inner packing ring containing the highest radioactivity.

Standardized RP Junior Task Qualifications Study Guide  
Lesson RP01.01 Revision 2

EO: 1.66 Describe radiological hazards associated with pump and valve maintenance and methods used to control them.

Radiological hazards associated with pump and valve maintenance is dependent on the system it is associated with. Those in direct contact with the Reactor Coolant system are going to have higher activity and additional requirements. Other systems that will require additional measures include the decay heat removal systems and radioactive waste, both liquid and gaseous, systems. However just because the system is not directly exposed to high activity does not alleviate the required radiological controls. Asking the questions such as:

- What system is the maintenance conducted on?
- What previous operating experience associated with the job?
- What previous survey data is available?
- Is anyone who has previously performed this job available for lessons learned?
- Are there any substantial changes since the last time the job was done? i.e., fuel failure, crud burst, etc.
- For a pressurized water reactor, consider the history of primary to secondary leaks.

Methods to control the radiological hazards include:

- The use of lead shielding for dose control.
- Containment devices for contamination control.
- Misting the surfaces to keep from creating airborne area.
- Evaluate the use of targeted ventilation.

Additional methods have been covered throughout the training such as:

- Putting together an ALARA plan
- Radiological Pre-Job Briefing
- Supervisory oversight
- Work Packages
- Radiological Hold Points
- Monitoring of the workers locally and remotely

**Standardized RP Junior Task Qualifications Study Guide**  
**Lesson RP01.01 Revision 2**

EO: 1.67 Define the terms “excitation,” “ionization,” “secondary ionization” and “specific ionization

*Excitation* is where the radiation deposits energy into an atom raising its energy level but not enough energy to eject a bound electron. Atoms make up the cells that make up the tissues of the body. Any potential radiation damage begins with damage to atoms.

*Ionization*

Radiation can be classified into two general groups, charged and uncharged; therefore, it may be expected that interactions with matter fall into two general types. Charged particles directly ionize the media through which they pass, while uncharged particles and photons can cause ionization only indirectly or by secondary radiation.

A moving charged particle has an electrical field surrounding it, which interacts with the atomic structure of the medium through which it is passing. This interaction decelerates the particle and accelerates electrons in the atoms of the medium. The accelerated electrons may acquire enough energy to escape from the parent atom. This process, whereby radiation "strips" off orbital electrons, is called ionization. Uncharged moving particles have no electrical field, so they can only lose energy and cause ionization by such means as collisions or scattering. A photon can lose energy by the photoelectric effect, Compton effect, or pair production.

The electrons that circle the nucleus move in fairly well-defined orbits. Some of these electrons are more tightly bound in the atom than others. For example, only 7.38 eV is required to remove the outermost electron from a lead atom, while 88,000 eV is required to remove the innermost electron. The process of removing an electron from an atom is called ionization, and the energy required to remove the electron is called the ionization energy.

*Secondary Ionizations* occur due to the ion pairs accelerated to the anode and cathode because of the difference in voltage, as the ion pairs cause additional ionizations, or secondary ionizations, if the voltage is high enough

*Specific Ionization* is the number of ion pairs produced per distance traveled.

The energies associated with radiations are given in terms of "million electron volts" (MeV). Beta emissions may occur with energies to about 5 MeV; alphas to about 10 MeV; and gamma photons to about 3 MeV. The energy of the particulate radiations is manifested as kinetic energy--the higher the energy the greater the velocity of the particle. However, the velocity of photons is constant ( $c$  = speed of light) and energy differences are manifested by varying wavelengths and frequencies. The other characteristic aspect associated with decay patterns is the rate of decay, or activity.

**Standardized RP Junior Task Qualifications Study Guide**  
**Lesson RP01.01 Revision 2**

The disintegrations of radionuclides occur with a regularity characteristic for each particular species. Such disintegrations are spontaneous and random. A single radium nucleus, for instance, may disintegrate at once or wait thousands of years before emitting an alpha particle. All that can be predicted with any certainty is that half of all the  $^{226}\text{Ra}$  nuclei present will disintegrate in 1,622 years. This period is called the half-life of  $^{226}\text{Ra}$ . Half-lives vary greatly for natural occurring radioisotopes, e.g.,  $^{212}\text{Po}$ , with a half-life of 0.298 microseconds and  $^{232}\text{Th}$ , with a half-life of over  $1.42 \times 10^{10}$  years.

EO: 1.68 Describe the processes and characteristics of heavy charged particles' (for example, alpha particles, protons) interaction with matter.

- energy transfer by ionization and excitation
- range-energy relationship
- range of alpha particles in air, water, and tissue
- specific ionization as a function of distance

Photons are attenuated when the photons' energy is totally or partially absorbed, and that energy is transferred to an electron or nucleus. When photons interact with a target atom, only the intensity of the photon is attenuated while the incident beam or source is not. Photons are attenuated by photoelectric effect, Compton scattering, or pair production, depending on the energy of the photon.

Charged particles interact with matter, produce ion pairs, and lose energy. Alpha particles have the highest charge (2+) and are much heavier than beta particles. If an alpha and a beta particle have the same energy in MeV, the alpha particle will move much slower through the material than the beta particle due to its high positive charge (+2) and mass. Therefore, an alpha particle will spend a longer time traveling through a given material allowing it to lose all its energy in a very short distance when compared to a beta particle with only a single negative charge or a positron with a single positive charge. The figure above shows that an alpha particle loses its energy so fast, it cannot penetrate a piece of paper; while a beta particle still retains enough energy to pass through.

Charged particle interaction with matter has the following characteristics:

- Higher specific ionization as charge and mass are increased
- Less range as charge and mass are increased
- A given material will stop an alpha particle more readily than a beta particle
- Alpha particles produce 20,000 to 60,000 ion pairs per centimeter (cm) in air

**Standardized RP Junior Task Qualifications Study Guide**  
**Lesson RP01.01 Revision 2**

- Beta particles might produce 100 ion pairs per centimeter (cm) in air

The principal types of interactions for alpha particles are:

- Ionization
- Excitation

Usually have energies from 4 to 8 MeV

High specific ionization (because of their +2 charge and low velocity)

Lose their energy very quickly as they travel through matter.

Easy to shield – can be stopped by a piece of paper

Not an external hazard – cannot penetrate the dead layer of skin on the surface of the body

Potential internal hazard – the large radiation weighting factor for alpha particles (20) means that the consequence of a given alpha particle dose is greater than that for other types of radiation.

The range of an alpha particle is short:

- approximately 5 cm in air.
- 20 to 70  $\mu\text{m}$  in tissue (one, two or three cells)

EO: 1.69 Describe the processes and characteristics of beta particle interactions with matter.

- range-energy relationship
- energy transfer by ionization, excitation, and bremsstrahlung
- irregular track due to scattering
- bremsstrahlung production using high atomic number absorber
- range of beta particles in air, water and tissue

Beta particles, negatron, and positron are much lighter than alpha particles and at the same energy will move much faster. Because there is less time to interact with a target atom, energy will be transferred much more slowly, and a beta particle will travel farther than an alpha particle. Betas interact with the target atom through ionization of valence electrons as well as through elastic and inelastic scatter with orbital electrons. Observations of beta particle travel through a medium show that they have a more zigzag pattern rather than straight like an alpha particle; once enough energy has been removed from these collisions, a beta particle will be captured as a valence electron in one of the surrounding atoms in the medium it traveled through. Positrons are a result of gamma or nuclear transition and will be discussed later in the lesson.

Beta particle attenuation has additional phenomena that can be a personnel exposure hazard and must be considered: Bremsstrahlung, annihilation, and Cherenkov radiation.

Annihilation radiation occurs when a beta, or negatron, and its antiparticle, a positron, annihilate and release photons to satisfy conservation of energy.

#### Range and Penetration

- Beta particles (and electrons) travel in convoluted paths.
- They do not travel in a straight line.
- The “range” of a beta particle usually refers to the total path length.
- The range is greater than the distance between the beginning and the end of the path followed by the particle (the penetration thickness).
- In other words, the range of a beta particle is greater than the thickness of a material that can be penetrated.

### Standardized RP Junior Task Qualifications Study Guide Lesson RP01.01 Revision 2

*Bremsstrahlung* is a German word meaning “braking radiation”; when a beta particle gets close to an atomic nucleus, it will be sharply deflected and decelerated. This change in direction and negative acceleration causes gamma radiation to be emitted due to conservation of energy and momentum. The denser the material is, the more chance the beta particle will interact with a nucleus and be deflected; therefore, more dense materials could cause a hazard to workers due to the secondary gamma radiation given off from *Bremsstrahlung*.

- *Bremsstrahlung* is most significant for high energy beta emitters such as P-32 and Sr-90.
- The presence of *Bremsstrahlung* is often interpreted as an indication that high energy beta emitters are present.
- Nevertheless, *Bremsstrahlung* can be detected when low energy beta emitters (e.g., tritium) are present in high enough activities.
- Shielding a high energy beta source with lead could increase the production of *Bremsstrahlung*.
- Nevertheless, if the lead is thick enough, it will also stop the *Bremsstrahlung*.
- Sometimes a beta shield has two layers:
  - plastic nearest the source to stop any betas
  - lead outside the plastic to stop any *Bremsstrahlung*

#### Cherenkov Radiation

Cherenkov radiation is what causes the characteristic blue glow to spent nuclear fuel. The visible glow is akin to the sonic boom one would hear from a jet exceeding the speed of sound; however, in this case the beta particle exceeds the speed of light in the medium through which it is traveling (water in the case of spent nuclear fuel). For both Cherenkov and annihilation radiation, the hazard to a worker is low due to water’s shielding properties and the conditions that must be present for annihilation to occur; however, this is not the case for *Bremsstrahlung*.

Standardized RP Junior Task Qualifications Study Guide  
 Lesson RP01.01 Revision 2

EO: 1.70 Define fast neutron and thermal neutron

Since fission neutrons are born at high energies (fast neutrons), the probability that they will cause a fission while at that energy is very small; therefore, it is necessary to reduce this neutron energy to a value where the probability that it will cause fission is increased. This is accomplished by interposing relatively non-absorbing nuclei as collision media to reduce the kinetic energy of fission neutrons through the process of scattering. This medium is called the "moderator." It acts to moderate (slow down), or "thermalize" the fission neutrons.

Typical moderators are hydrogen, beryllium, and carbon. Fewer collisions are necessary in a hydrogen medium to cause complete moderation than in carbon, since the atomic mass of hydrogen is smaller, and therefore, able to absorb more kinetic energy from the neutron during the scattering process. The following description is analogous to this scattering process:

If moving billiard ball A strikes stationary billiard ball B, ball B moves away, and ball A will come to rest. If billiard ball B is replaced by a bowling ball, moving ball A bounces off, barely transferring any energy to the bowling ball. A neutron-proton collision is like a two billiard ball collision and a neutron-carbon collision is like a billiard ball-bowling ball collision.

The amount of moderator in a reactor greatly influences the slowing down process. If there is too little moderator, the neutrons are not adequately thermalized. Hence, the probability of fission is reduced as more neutrons will either leak out of the core or be absorbed in non-fissioning materials. If there is too much moderator, the probability that a thermal neutron will be captured by the moderator is greatly increased.

Some number of the fast neutrons produced by fission in one generation will eventually cause fission in the next generation. The series of steps that fission neutrons go through as they slow to thermal energies and are absorbed in the reactor is referred to as the neutron life cycle. The neutron life cycle is markedly different between fast reactors and thermal reactors. This chapter presents the neutron life cycle for thermal reactors.

Neutron type	Energy Level <sup>1</sup>
Fast	>1.0 MeV
Intermediate	1.0 MeV to 1.0 eV
Slow	<1.0 eV

<sup>1</sup> The energy level values can vary depending on the technical reference, these values were obtained from Nuclides and Isotopes, 17<sup>th</sup> Edition Knolls Atomic Power Laboratory

Standardized RP Junior Task Qualifications Study Guide  
Lesson RP01.01 Revision 2

Also review information in objective 1.11

**INITIATING DOCUMENTS**

INPO ACAD 93-008 - Guidelines for Training and Qualification of Radiation Protection Technicians

Efficiency Bulletin: 17-01 Portable Supplemental Radiation Protection Technician Training and Qualification

NISP-RP-12, Training and Qualification of Supplemental RP Technicians

**CONTENT REFERENCES**

DOE Fundamentals

10 CFR 20, Standards for Protection Against Radiation

DOE-STD-1098-99, Radiological Control

DOE-HDBK-1130-2008, Radiological Worker Handbook

DOE-HDBK-1122-2009, Radiological Control Technician Training [www.NRC.gov](http://www.NRC.gov) website

Regulatory Guide 8.4, METHODS FOR MEASURING EFFECTIVE DOSE EQUIVALENT FROM EXTERNAL EXPOSURE

Bechtel Seventeenth Addition for Nuclides and Isotopes

**REVISION COMMENTS**

April 17 <sup>th</sup> , 2023	Theodore J Green-EPRI	Author
EO: 1.63	Compare the operating characteristics of centrifugal pumps with those of positive displacement pumps	Added the additional objectives from Revision 4 of NISP-RP-12.
EO: 1.64	Identify the type of valve, the major components of the valve and packing assembly, given an unlabeled cross-sectional diagram of the valve	Added the additional objectives from

Standardized RP Junior Task Qualifications Study Guide  
Lesson RP01.01 Revision 2

EO: 1.65	Explain why the innermost packing ring inside a leaking radioactive system valve will generally exhibit the highest dose rate and contamination levels	Revision 4 of NISP-RP-12. Added the additional objectives from Revision 4 of NISP-RP-12.
EO: 1.66	Describe radiological hazards associated with pump and valve maintenance and methods used to control them.	Added the additional objectives from Revision 4 of NISP-RP-12.
EO: 1.67	Define the terms “excitation,” “ionization,” “secondary ionization” and “specific ionization”	Added the additional objectives from Revision 4 of NISP-RP-12.
EO: 1.68	Describe the processes and characteristics of heavy charged particles’ (for example, alpha particles, protons) interaction with matter. <ul style="list-style-type: none"> <li>• energy transfer by ionization and excitation</li> <li>• range-energy relationship</li> <li>• range of alpha particles in air, water and tissue</li> <li>• specific ionization as a function of distance</li> </ul>	Added the additional objectives from Revision 4 of NISP-RP-12.
EO: 1.69	Describe the processes and characteristics of beta particle interactions with matter. <ul style="list-style-type: none"> <li>• range-energy relationship</li> <li>• energy transfer by ionization, excitation and bremsstrahlung I</li> <li>• irregular track due to scattering</li> <li>• bremsstrahlung production using high atomic number absorber</li> <li>• range of beta particles in air, water and tissue</li> </ul>	Added the additional objectives from Revision 4 of NISP-RP-12.
EO: 1.70	Define fast neutron and thermal neutron	Added the additional objectives from Revision 4 of NISP-RP-12.